

The SAX-6 Area Alarm for Piped Medical Gases

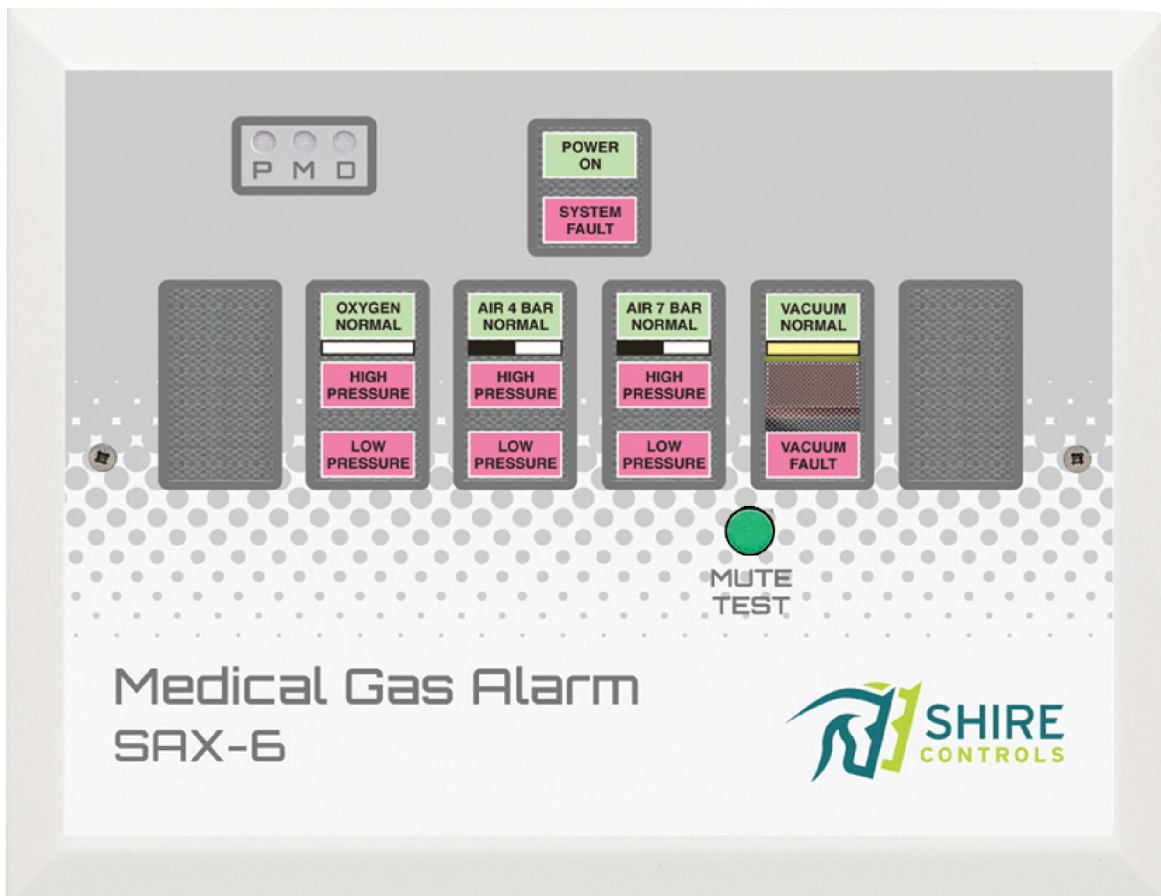

CE

SHIRE
CONTROLS

INTRODUCTION

The SAX-6 area alarm panel is designed to monitor high & low pipeline pressure on up to 6 gases, using volt-free, normally closed, contacts on pressure sensors mounted in the pipeline downstream from the final Area Valve Service Unit (AVSU). Each gas has a green "Normal", red "High Pressure" and "Low Pressure" lamps. The panel also has a green "Power On" lamp and a red "System Fault" lamp, together with a mutable audible alarm. In addition, the panel has small status indicators to show how the panel is connected, and the status of the connection.

The SAX-6 can also receive and transmit data from & to the MEDCON bus as used by the SDX-15 plant alarm system. Note. An additional adaptor, which plugs into the main PCB, is required for operation with the SDX-15 system.

OPERATOR

The SAX-6 Area Alarm is designed for manual operation via the Test/Mute push-button. Hence it is envisaged that the operator is able to visually monitor from within 900mm.

The inherent design includes Red/Green indicator LED's and the use of gas colour recognition within the title bar of each gas window, which ensures that the alarm can be monitored comfortably from 3-4 metres away. Consideration should be made for final location, in accordance with the latest HTM guidelines, prior to installation.

About this manual



When you see this symbol, the associated text in bold type refers to something which may cause damage or danger.

MOUNTING

Remove the 2no M3 fascia screws and lift the cover clear. Disconnect the earth cable from the rear of the cover.

For Surface mount unit, remove the PCB by removing the 2no M4 earth screws (and crinkle washers) on the lower edge of the PCB and releasing the 2 clips on the upper edge. For Flush mounting alarm, the PCB can be removed by unscrewing the countersink screw and removing the washer from the 3no spring pillars.

Finally, unplug the mains flex.



Always ensure that you are in contact with earth when handling electronic components to avoid damage by static discharges.

If cable entry is from behind the panel, remove the two knock-outs in the back of the panel. Mount the panel with the TOP label uppermost, using the 4 holes provided.

Mount the termination box (if used) adjacent to the pressure switches (contact source). Plug the connectors on the flexes onto the pressure switches. Connect the 3 core screened cable from the alarm panel into the terminals marked A, B & C, ensuring that the screen is clamped using the

copper clip provided.

CABLING

The following connections are required:-

A 240 volt 50/60 Hz supply, fused at 3 amps.

This equipment is not suitable for connection to an IT power system. A readily accessible means of disconnecting the supply must be provided. The maximum prospective fault current must not exceed 1500 amps.



If the panel is to receive data directly from pressure switches, a 3 core screened cable, minimum 0.5 square mm CSA, is required between the panel and the termination box.

If the panel is to be connected to an SDX-15 system, a 2 core screened cable, minimum 0.5 square mm CSA, is required between the panel and the nearest point on the SDX-15 system.



All cable screens must be connected at both ends. Continuity must be maintained through any junction boxes. A minimum of 20mm clearance must be maintained between the alarm system cabling and any other cables (including the 230Vac to the alarm system).

FAILURE TO CARRY OUT THESE INSTRUCTIONS MAY CAUSE INTERMITTENT FAULTS AND INVALIDATES THE DECLARATION OF CONFORMITY RELATING TO THIS ALARM.

CONNECTING

The terminals for termination box & Medcon connections can be unplugged for easy connection, by pulling the terminal downwards.

Connect the termination box to the three terminals marked PSW A B C. Also connect any other repeater SAX-6 alarms panels which are to work with the same termination box (up to a maximum of 5 repeater panels).

Connect the SDX-15 system (if used) to the terminals marked MEDCON 1 2.

Connect live, neutral & earth to the terminals marked L N and .

CONNECTING SCREENS

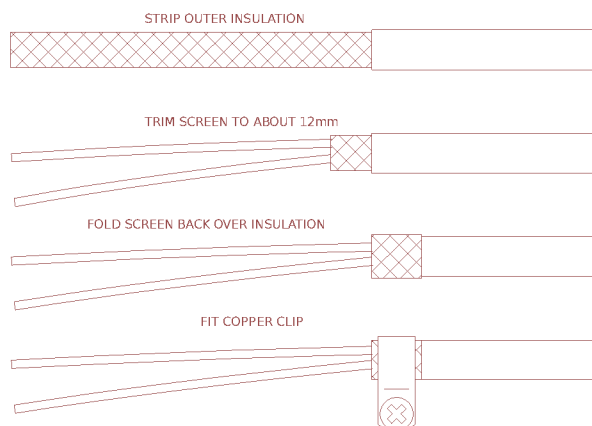

Replace the PCB by plugging in mains flex.

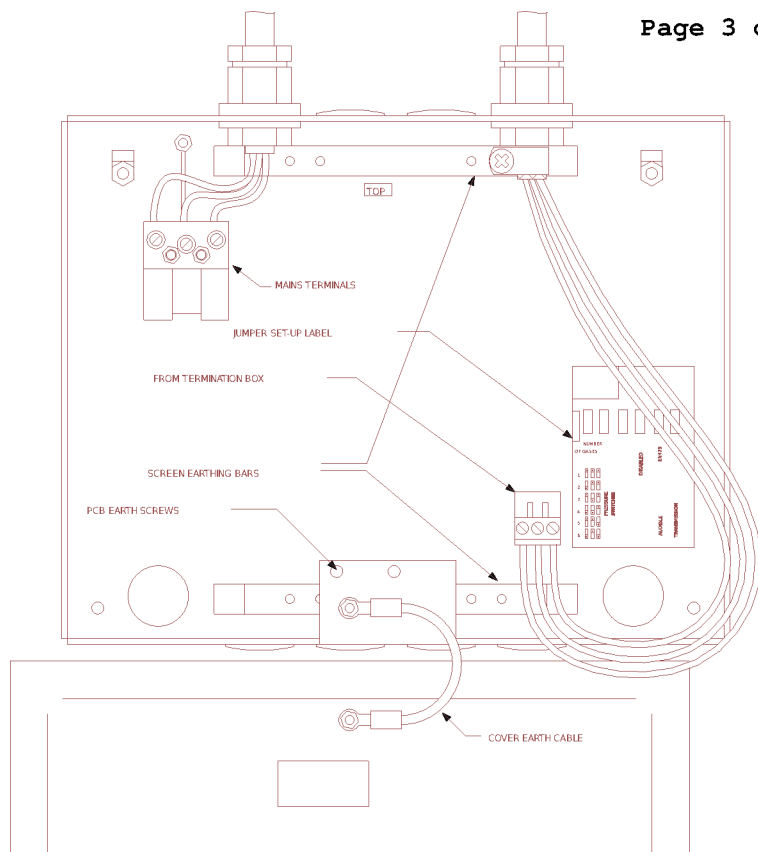

For Flush Alarms, locate the 3no sprung pillars with mounting holes (top left & top right & centre bottom of PCB) and replace M3 washer and countersunk screws. For Surface Alarm, press PCB onto the top 2no mounting clips and replace 2no M4 screws on lower edge (& crinkle washers).

Plug in 3way terminal (& 2way in needed), previously removed for connection. Switch on mains supply & fit battery isolating jumper across the 2 pins on front of PCB, bottom right of speaker.

SETTING UP

Set the 6no jumpers as follows (the settings are shown on the label in the back box):-

Jumpers 1,2 & 3 for number of gases. You will not normally need to change these.

Jumper 4 for pressure switches. Enable this if you are connecting via a termination box

Jumper 5 for audible. Set to EN475 to enable the European standard audible type, or HTM02 to enable the HTM02 two-tone audible type.

Jumper 6 Transmission. This is only used when transmitting or receiving data from the SDX-15 alarm system. "All" sets the panel to transmit all alarm conditions, "Common" sets the alarm to transmit just a single common fault condition. See page 5 for setting up data transmission.

Set the volume control to the required by using a small terminal screwdriver and rotating.

Replace cover & ensure earth-lead is in place.

PRIORITY SIGNALS

All normal conditions are represented by Green LEDs (i.e. "Power On" if 230Vac is present and "Normal" when neither fault on a gas is present).

All fault conditions are represented by flashing Red LEDs. A "System Fault" is displayed if there is a A/B/C cable fault or loss of 230Vac detected. Gas level warnings are displayed if any

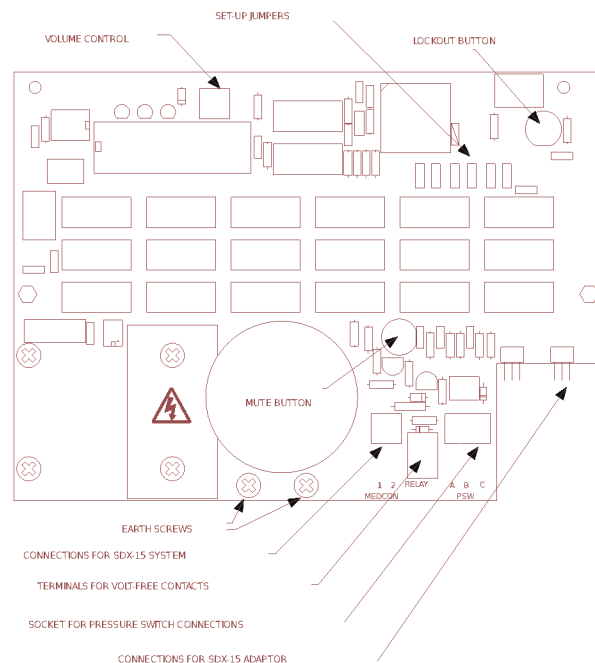

gas pressure is out of pre-set operating range.

OPERATION

When a pressure switch opens due to a high or low pressure, the appropriate lamp will flash & audible will sound. Operating the mute button will silence the audible. If the alarm condition remains, the audible will re-trigger after a nominal 15 minutes.

If an alarm condition will be present for an extended period, the alarm condition can be permanently muted. Here, remove the cover while the alarm condition is present and operate the lockout button. Replace the cover. You can check which alarm conditions are locked out by holding in the mute button. An alarm condition which is locked out will not flash, other alarm conditions will flash (Note: "System Fault" cannot be locked out).

If pressure switch input is enabled (using the jumper) and no signals are received from the termination box, the red indicator marked "P" in the top left hand side of the alarm will flash, the "System Fault" lamp will flash, all alarm conditions will go to fault and the audible will sound. If signals are present, the "P" indicator will be on continuously. If pressure switch input is not selected, the "P" indicator will be off.

If an SDX-15 adaptor is fitted, it will be detected by the alarm panel. If no SDX-15 signals are detected, the indicator marked "M" will flash, the "System Fault" lamp will flash and the audible will sound. If signals are present, the "M" indicator will be on continuously. If no adaptor is detected, the "M" indicator will be off.

During power failure, the internal battery will run the alarm. To conserve power, the lamp current is reduced, resulting in a drop in brightness. The audible will sound and the "System Fault" lamp will flash. If the mains power is off for a prolonged period and the audible is not muted, all lamps will go out to conserve power.

Cable types

Use only the following types of cable for wiring the alarm system:-

SWA

Overall screened cable

Single core cable in steel conduit. **Must not contain any other cables.**

Min. core size of 0.5 sq.mm CSA is recommended. Solid cable, i.e. telephone cable should NOT be used.



Continuity of screen, armouring or conduit must be maintained at all times.

Particular attention should be given to plastic junction boxes.

Multi-core cables must not be shared with other systems.

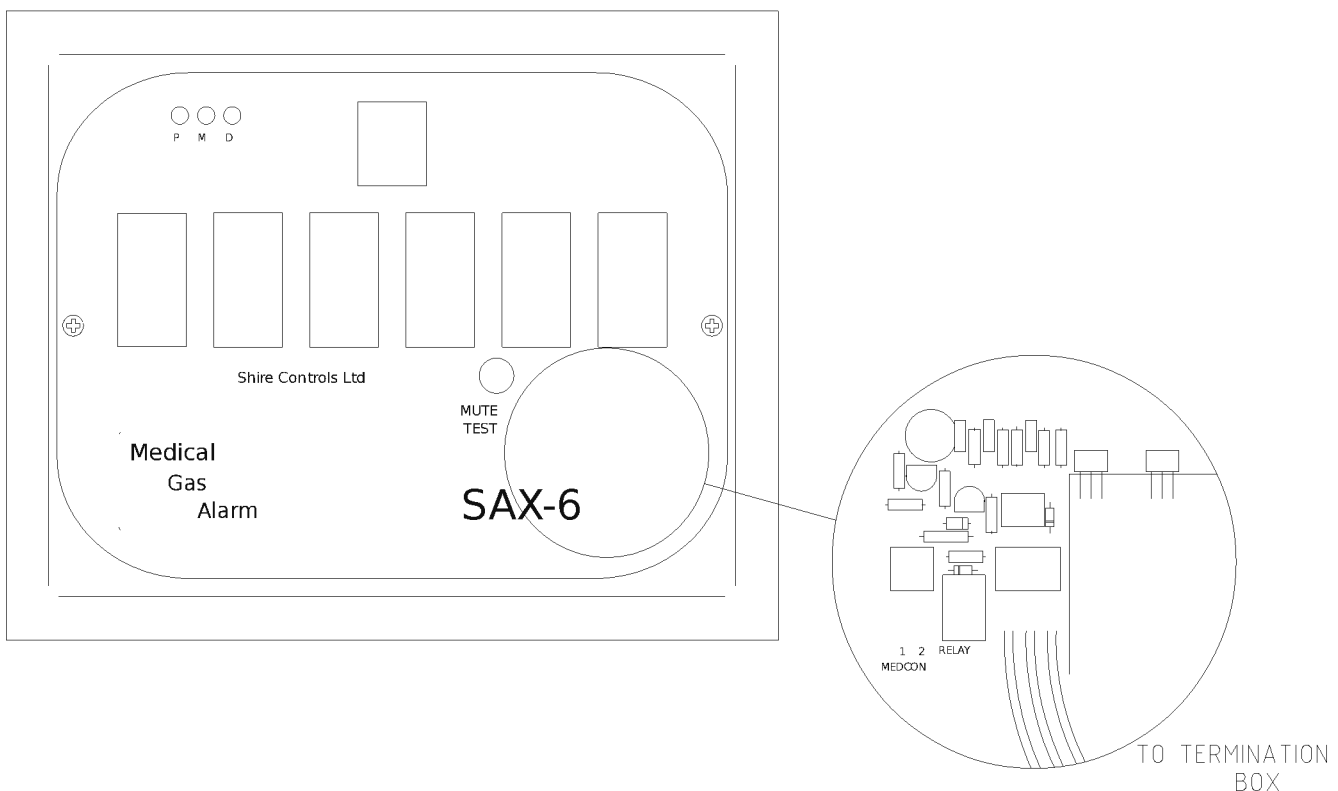
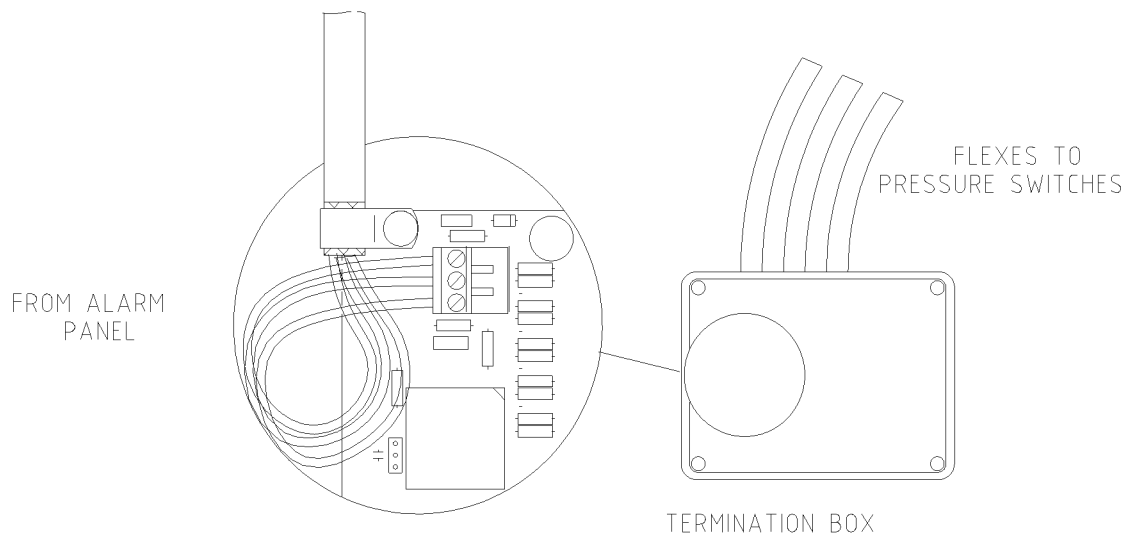

SETTINGS FOR MEDICAL APPLICATIONS

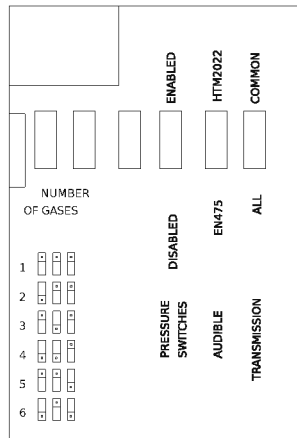

SETTINGS FOR INDUSTRIAL APPLICATIONS

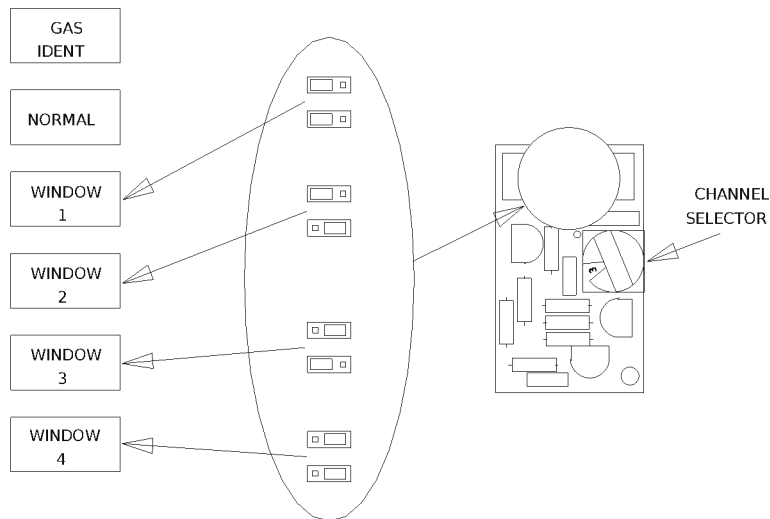
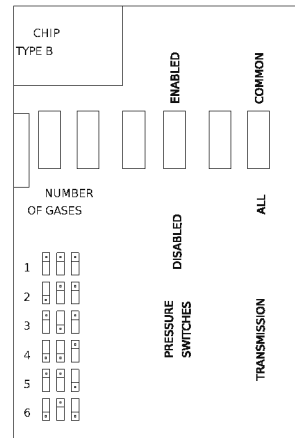

SETTINGS FOR USE WITH SDX-15 SYSTEMS

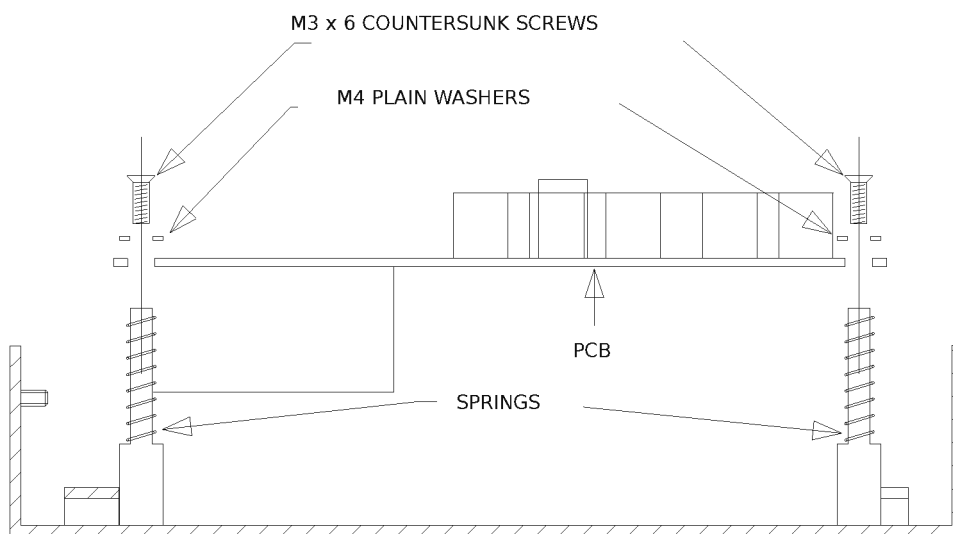

PCB FITTING FOR FLUSH MOUNTING PANELS

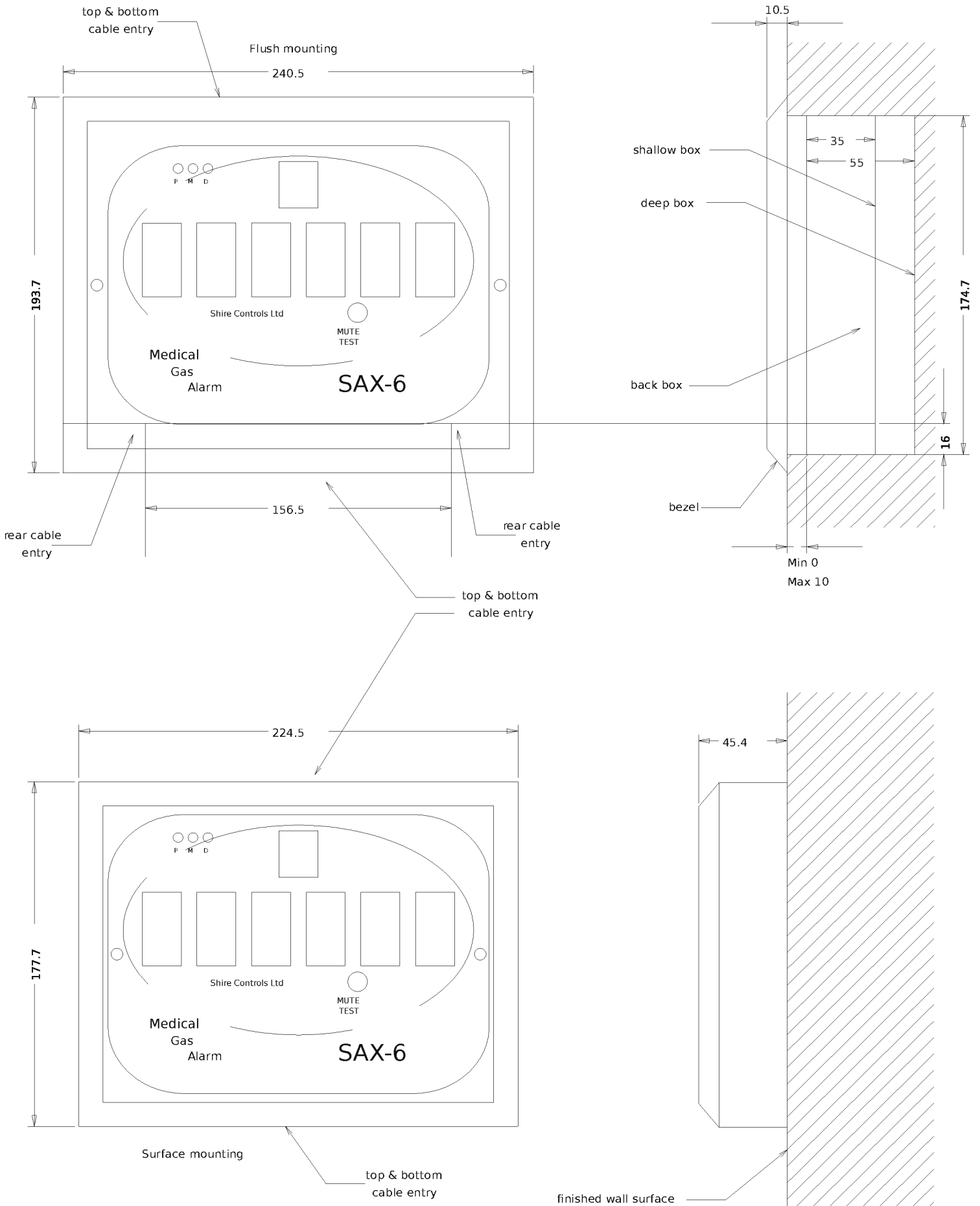

DECLARATION OF CONFORMITY

EU EMC Directive 2014/30/EU

The Low Voltage Directive 2006/95/EG

Medical Devices Directive 93/42/EEC

Manufacturer

Shire Controls Ltd
Studio 3 Channoeks Farm,
Gilston, Harlow
Essex CM20 2RL
United Kingdom

Product Type

SAX-6 Area Alarm System

Year of manufacture

2019

Standards used

To which this declaration relates is in conformity with the following standards:

EN60601-1-2 4th Edition 2015

Emissions Standard for Medical Equipment

EN55011, Class A 2016 + A1:2017

Emissions Standard for ISM Equipment

EN60601-1-2 4th Edition 2015

Immunity Standard for Medical Equipment

EN61000-4-2 2009

ESD Requirements

EN61000-4-3 2006 + A1 + A2

Radiated Susceptibility

EN61000-4-4 2016

Electrical Fast Transient Burst Requirement

EN61000-4-5 2017

Surges Requirements

EN61000-4-6 2014

Conducted Susceptibility

EN61000-4-8 2012

Magnetic Field Immunity

EN61000-4-11 2017

Voltage Dips and Interruptions

Authorised representative

I.R.Couchman Technical Director

Signature



This work is licensed under the Creative Commons Attribution-NonCommercial 2.5 License. To view a copy of this license, visit <http://creativecommons.org/licenses/by-nc/2.5/> or send a letter to Creative Commons, 543 Howard Street, 5th Floor, San Francisco, California, 94105, USA.



Shire Controls Ltd
Studio 3, Channoeks Farm
Gilston
Harlow
Essex
CM20 2RL

Tel. (01279) 434399

Fax. (01279) 451706

Website:

www.shirecontrols.com