

mk2 Duplex Anaesthetic Gas Scavenging System

Installation, Operation & Maintenance

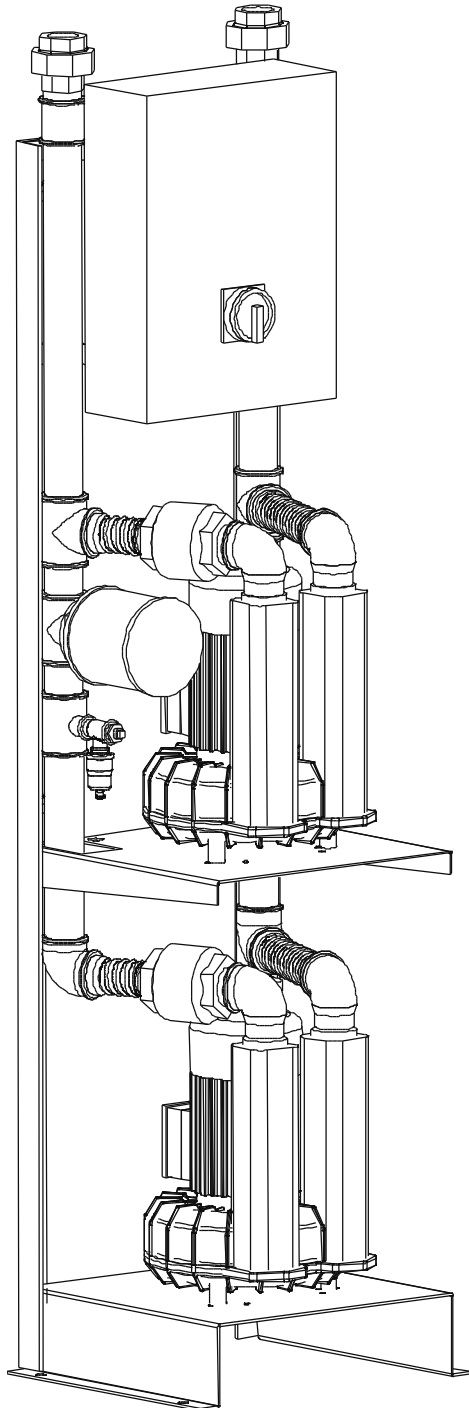

CONTENTS

Plant general layout	2
Typical Duplex AGSS system	3
Operating Environment	4
Mounting	4
Electrical connections	4
Setting up	5
Three phase site connections	6
Three phase circuit diagram	7
Single phase site connections	8
Single phase circuit diagram	9
Control panel circuit diagram	10
Operation	11
Maintenance	11

Shire Controls Ltd

Studio3, Channoeks Farm

Gilston

Harlow

Essex

CM20 2RL

UK

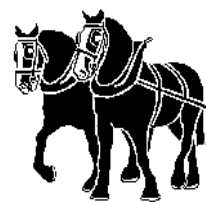

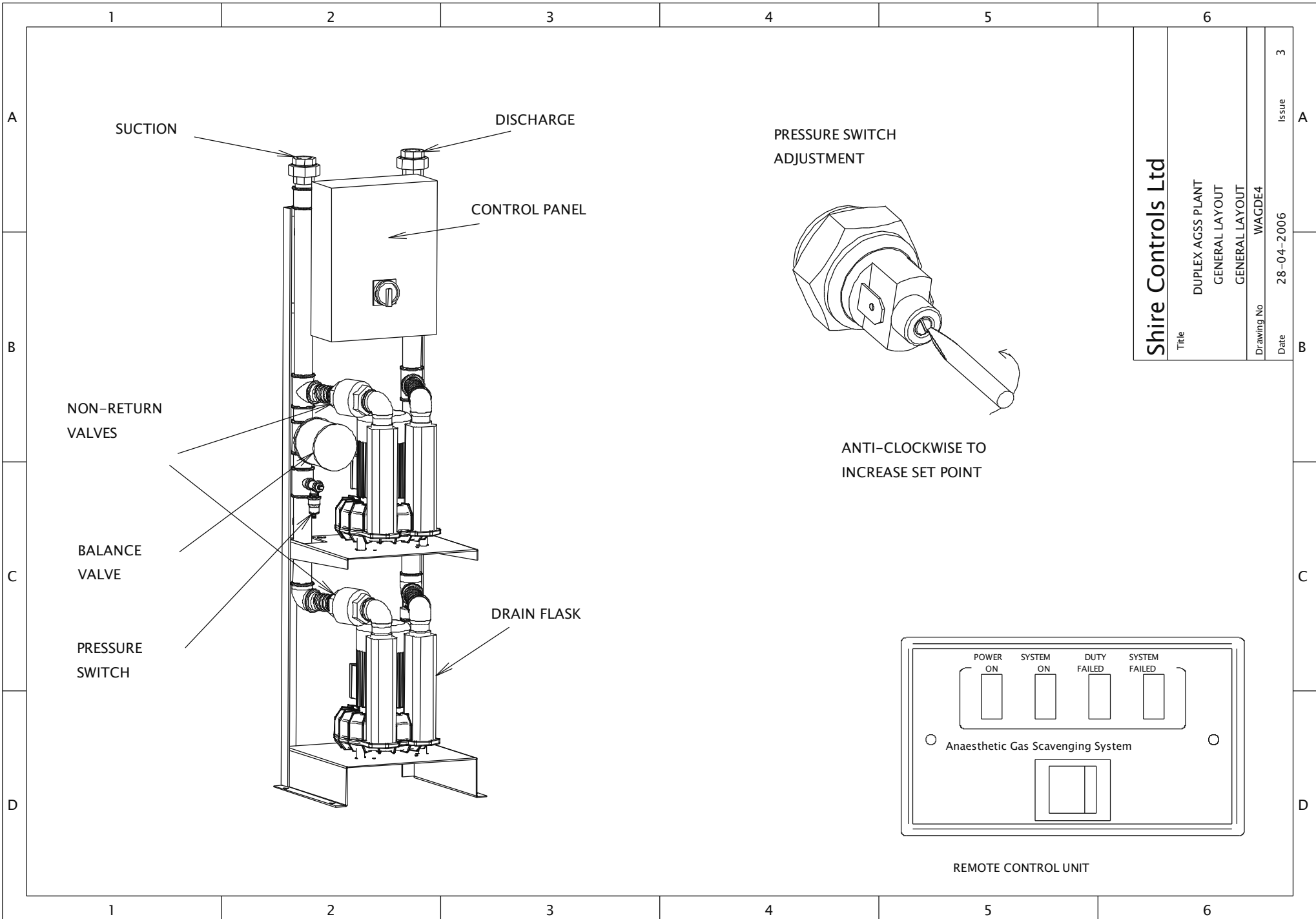

Shire Controls Ltd

Title
 DUPLEX AGSS PLANT
 GENERAL LAYOUT
 GENERAL LAYOUT

Drawing No

WAGDE4

Date

28-04-2006

Issue

3

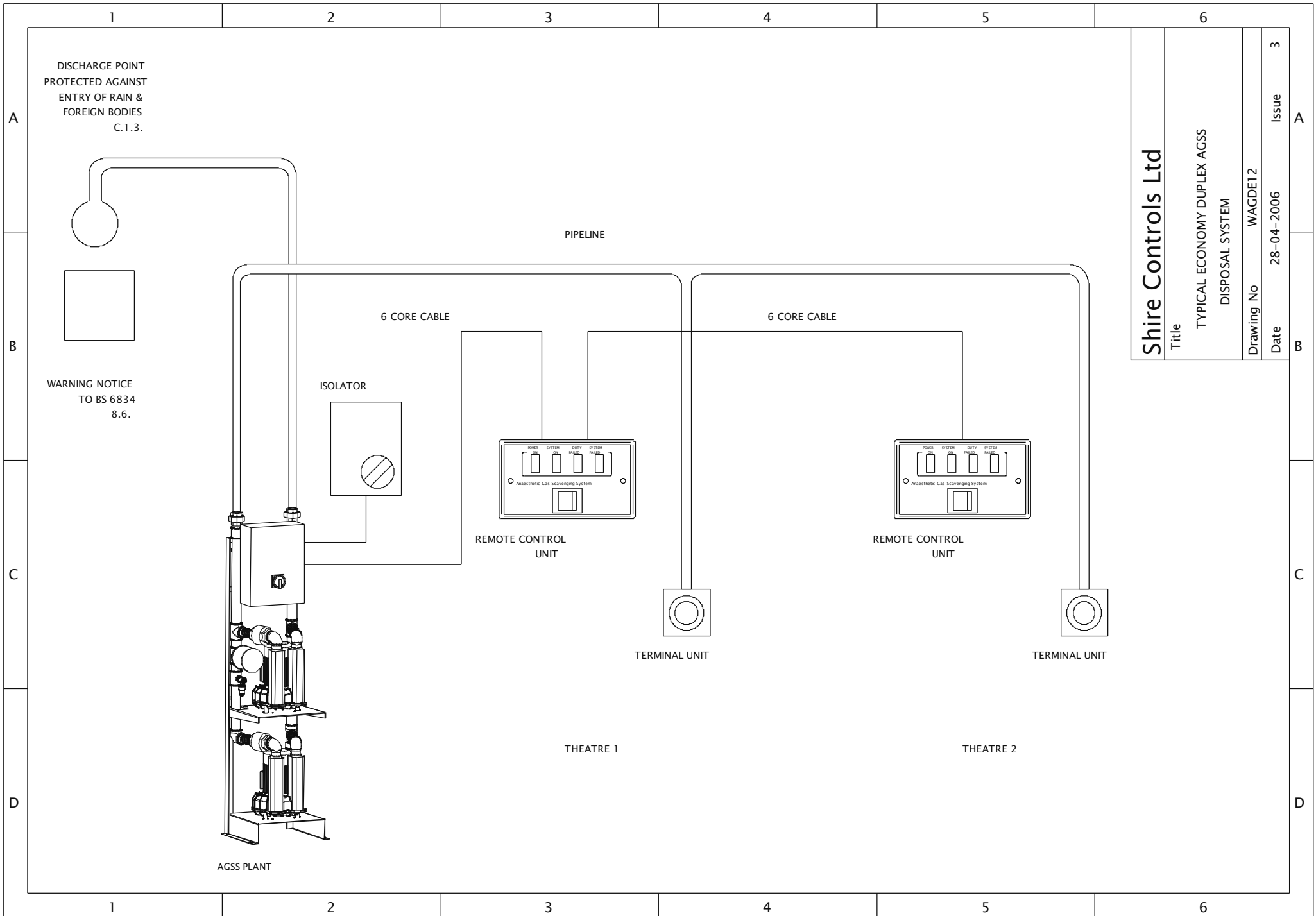

Shire Controls Ltd	Title	TYPICAL ECONOMY DUPLEX AGSS DISPOSAL SYSTEM
	Drawing No	WAGDE12
	Date	28-04-2006
	Issue	3

About this manual.



When you see this symbol, the associated text in **bold type** refers to something which may cause danger or damage.

Environment.

This plant is designed to be used in a dry environment with no abnormal levels of airborne dust. It is designed to work within the following parameters.

Temperature +5 to +35 deg. C. (+40 deg. C. maximum)

Max. Humidity 90% RH

Max. Altitude 1000m above sea level

Mounting.

Consideration should be given to the likelihood of the plant being struck by passing traffic & additional protection provided if necessary. The plant must be fixed by means of the four



mounting holes in the frame of the plant. Ensure a free flow of air to the motor. **If the plant is mounted in an enclosure, allow a minimum of 3 cubic metres per kilowatt of motor power of air space within the enclosure.**

Electrical Connections.



The plant must be supplied from an isolator complying with EN60947-3, category AC-23B, with provision for locking in the OFF position, mounted between 0.6 and 1.9 metres above the servicing level in an easily accessible position. The prospective fault current must not exceed 1.5kA. The earth fault loop impedance of the supply at the plant terminals must not exceed 1 ohm. Bond the earth bonding terminals on the pipework assemblies together, and bond between pipework assembly terminal and the bonding terminal at the rear of the frame.

Type	Power (kW)	Current (1 phase)	Current (3 phase)
SAP90	0.55	4.3	1.75
SAP110	0.75	6.2	2.5
SAP150	1.1	9.2	3.3
SAP180	1.5	9.5	5.0
SAP220	2.2	n/a	7.0
SAH55	0.75	6.9	2.3
SAH75	1.1	9.2	3.3
SAH95	1.5	9.5	5.0

Three phase plant.

Note. This plant requires a neutral. See Drawing WAGD8

Single phase plant.

See Drawing WAGD10

All plant.



Replace fuses only with motor rated fuses, rated at the motor full load current. Do not use this plant with any control, indication or interface system other than that supplied by the manufacturers. A relay interface is available giving volt-free contacts rated at 5 amps, 240 volt resistive, for Power on, System

on , Duty Failed and System Failed signals, and providing input terminals for control from volt-free contacts. When using remote control units or relay interfaces, connect the terminals on the lower edge of the printed circuit board in the control panel marked RUN, SF, SIU, -Ve, +Ve & CTL to the corresponding terminals on the remote control units or relay interfaces. A maximum of 6 remote control units may be used with a control panel. The voltage drop on the cable to the remote control units should not exceed 1.2 volts.(the current drawn is .017 amps per remote control unit + .03 amps . 6 remote control units could be used on 300 M of 1.5mm



cable) Cable exceeding 2.Smm should not be used. When using a relay interface, connect the terminals marked "Local" on the relay interface to the contacts which will control the plant e.g. theatre panel switch. **These contacts must be volt-free.**

Use the contacts on the relay interface to switch other circuits as required. When using the relay interface to switch indicator lamps on theatre panels etc. we strongly recommend that System On, Duty Failed and System Failed conditions are displayed as a minimum, and that lamps are used which are of equal brightness and reliability to the lamps used on the standard remote control unit, When not using remote control units or relay interfaces, link the terminals marked +Ve & CTL.

Setting up.

Check the rotation of the motors on three phase plant. If the rotation is incorrect, isolate the supply and reverse two phases. With all remote control units switched off, check that the pumps are not running and that all remote control units and the control panel show a Power On lamp. Switch on the local off switch on the control panel. Switch on each remote control unit in turn. As the pump switches on, the System Failed lamp will come on momentarily as the pump produces vacuum in the pipeline, followed by the System On lamp. Switch off this remote control unit & continue to the next. If the System failure lamp does not operate correctly, reset the pressure switch as follows. Disconnect the suction hoses from the plant. Switch on the plant. If the System Failure lamp is on, turn the pressure switch adjusting screw (see drawing WAGD4) clockwise until the System Failure lamp goes out. Turn the adjusting screw anti-`clockwise until the System Failure lamp comes on and continue for 3/4 turn. If the system is operated at a very low vacuum, it may be necessary to use a lower setting. Replace the suction hose and pressure switch cover. Disconnect the suction pipework assembly from the pipeline. Switch on a remote control unit. The duty pump should start with the System Failed lamp showing. Wait until the stand-by pump starts. Reconnect the suction pipework assembly. Go to each remote control unit in turn, switch on and check that the Duty Failed lamp is on. Reset the control panel with the reset button and check that the stand-by pump stops.

Set up the system flow as described in BS 6834, using the balance valve to set the operation vacuum in the pipeline.



IMPORTANT. Ensure that an air flow is maintained through the pump via the balance valve when all terminal outlets are closed. Failure to allow an air flow will result in overheating of the pump with possible damage to the pump, motor and hoses and possible injury to personnel. The following minimum flow rates should be observed.

SAP90	150 l/m	SAP220	1700 l/m
SAP110	700 l/m	SAH55	200 l/m
SAP150	700 l/m	SAH75	350 l/m
SAP180	800 l/m	SAH95	700 l/m

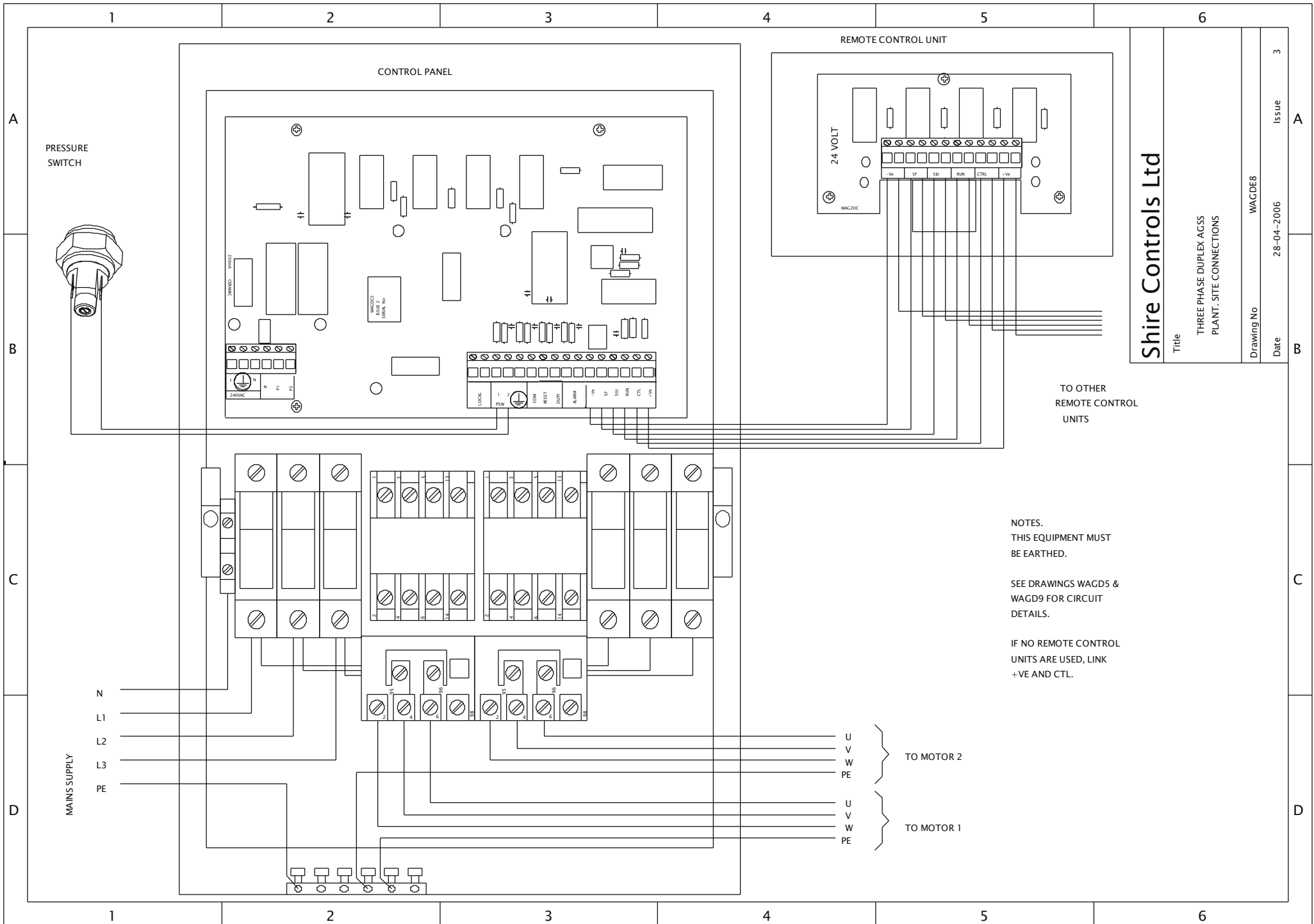

Shire Controls Ltd

Title
THREE PHASE DUPLEX ACSS
PLANT. SITE CONNECTIONS

Drawing No WAGDE8

Date 28-04-2006

Issue 3

TO OTHER
REMOTE CONTROL
UNITS

NOTES.
THIS EQUIPMENT MUST
BE EARTHED.

SEE DRAWINGS WAGD5 &
WAGD9 FOR CIRCUIT
DETAILS.

IF NO REMOTE CONTROL
UNITS ARE USED, LINK
+VE AND CTL.

U
V
W
PE
TO MOTOR 2

U
V
W
PE
TO MOTOR 1

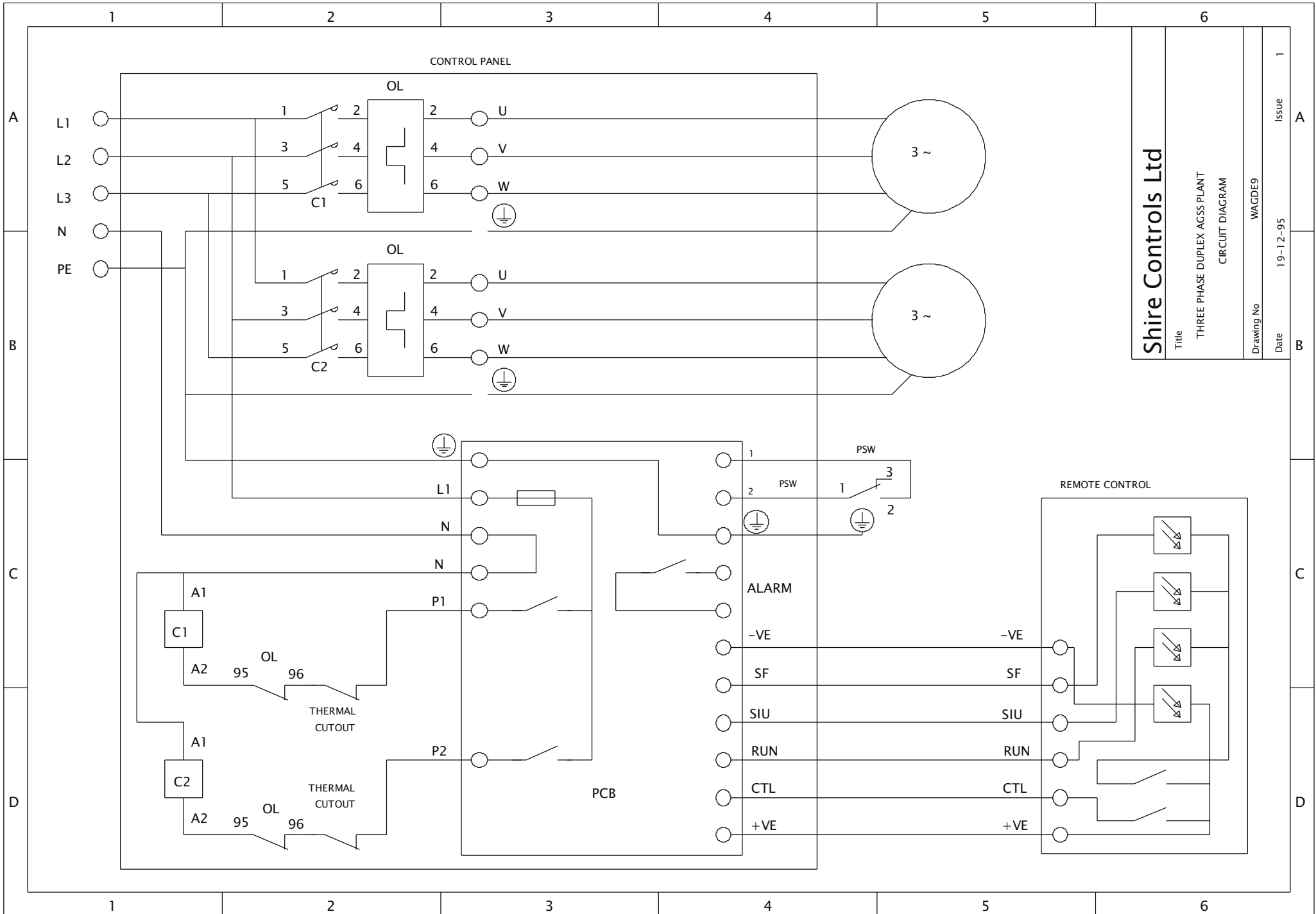

Shire Controls Ltd		Title	
		THREE PHASE DUPLEX ACSS PLANT CIRCUIT DIAGRAM	
Drawing No		Date	
WAGDE9		19-12-95	
Issue		1	

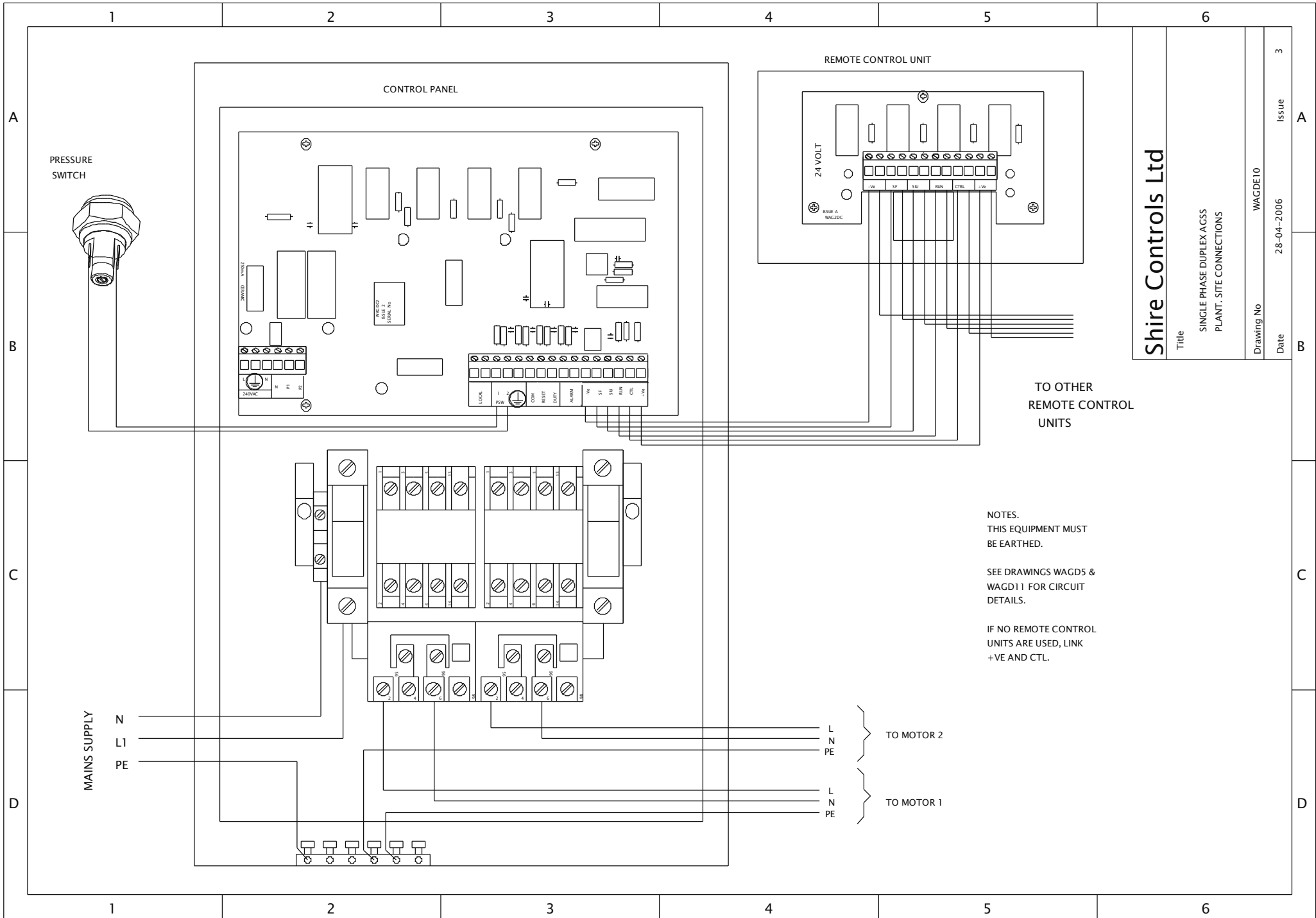

Shire Controls Ltd

Title
SINGLE PHASE DUPLEX AGSS
PLANT. SITE CONNECTIONS

Drawing No WAGDE10

Date 28-04-2006

Issue 3

TO OTHER
REMOTE CONTROL
UNITS

NOTES.
THIS EQUIPMENT MUST
BE EARTHED.

SEE DRAWINGS WAGD5 &
WAGD11 FOR CIRCUIT
DETAILS.

IF NO REMOTE CONTROL
UNITS ARE USED, LINK
+VE AND CTL.

TO MOTOR 2

TO MOTOR 1

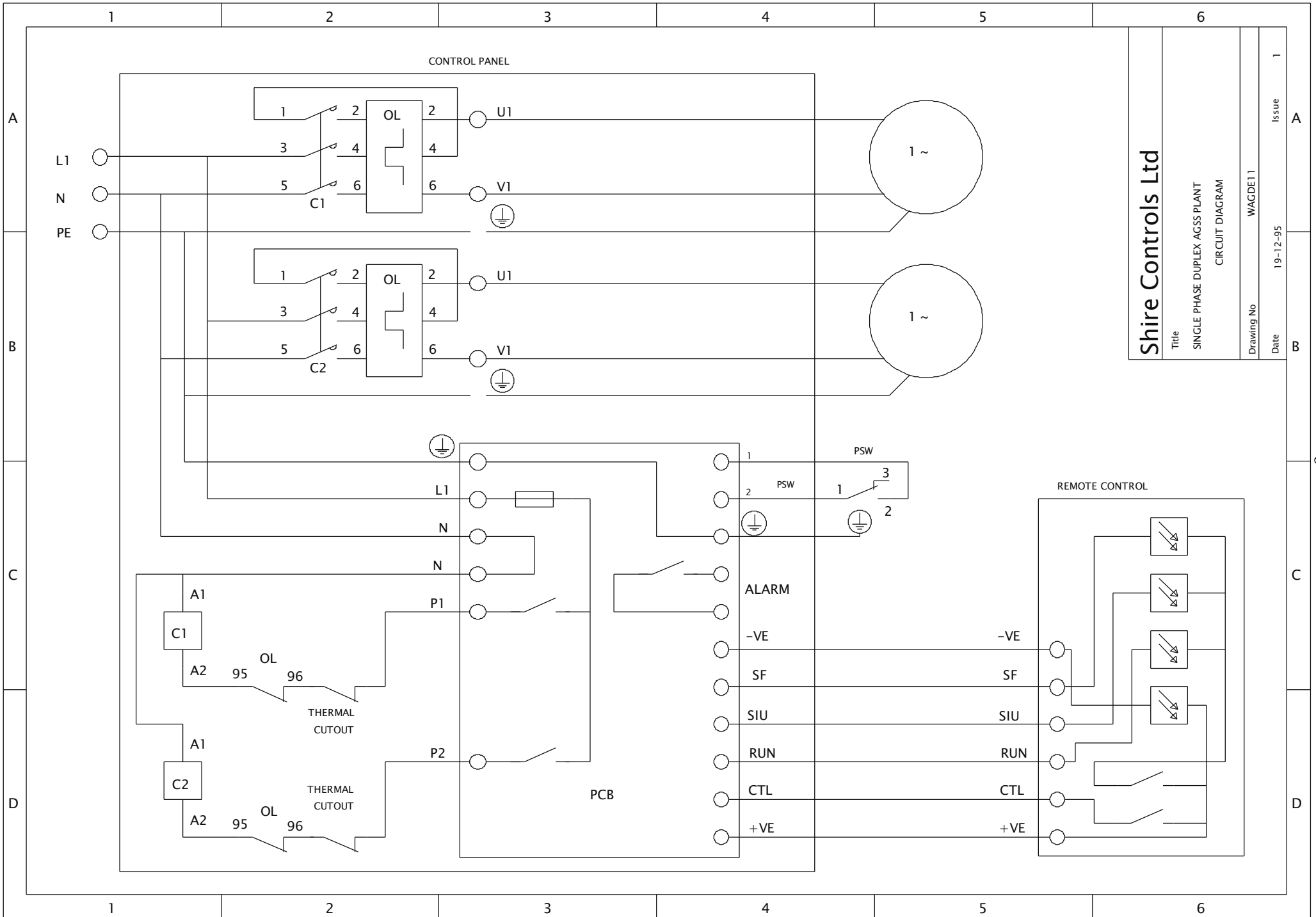

Shire Controls Ltd	
Title	SINGLE PHASE DUPLEX ACCESS PLANT CIRCUIT DIAGRAM
Drawing No	WAGDE11
Date	19-12-95
Issue	1

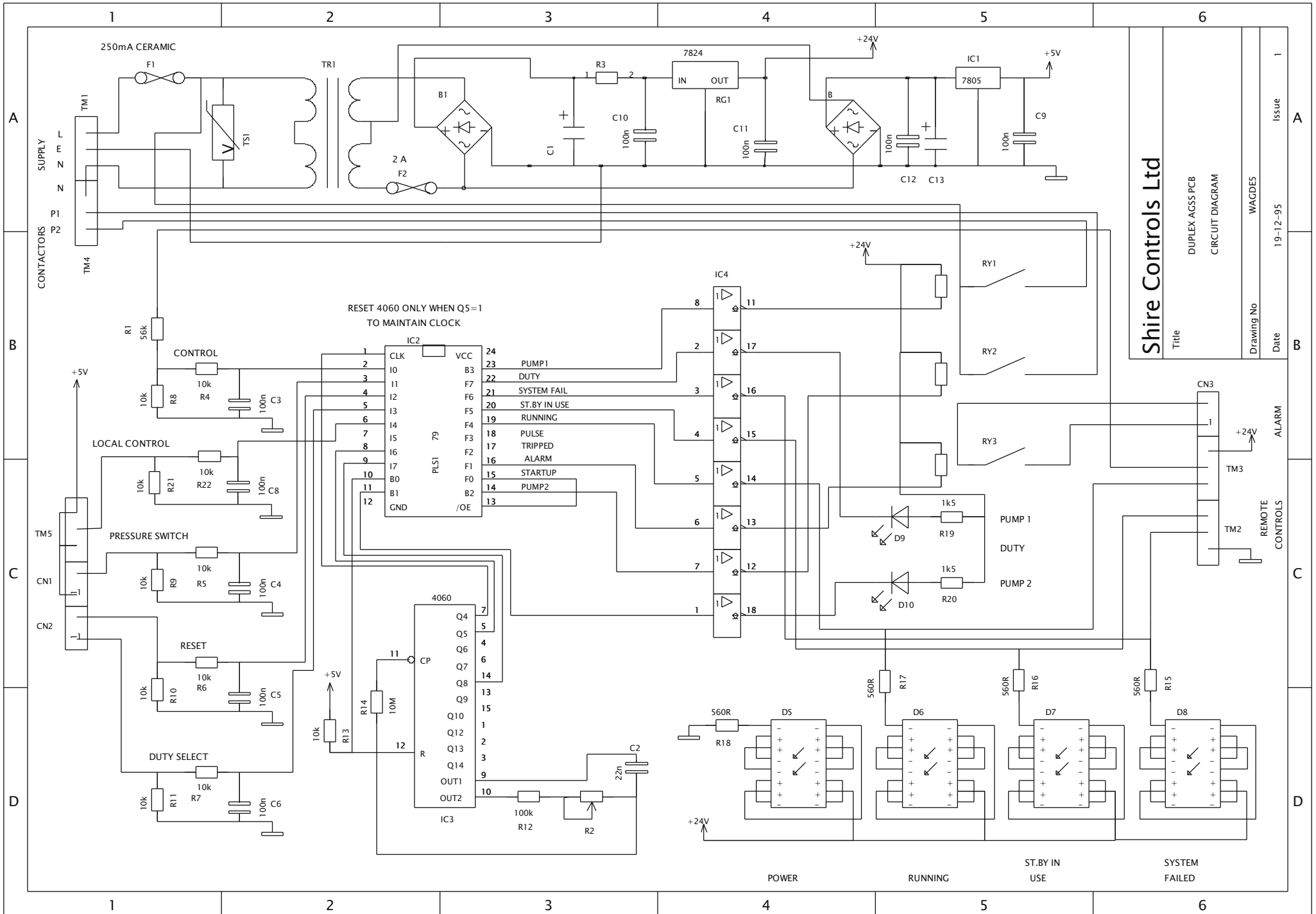

Shire Controls Ltd

Title
 DUPLEX AGSS PCB
 CIRCUIT DIAGRAM

Drawing No
 WAGDES

Date
 19-12-95

Issue
 1

Operation.

Switching on any remote control unit will start the plant. Indication of system on, duty failed or system failure will only be given at any remote control unit which is switched on. Any units switched off will show power on only. The plant will continue to run until all remote control units are switched off. The local off switch on the control panel will prevent the plant being started from a remote control unit if it is switched off. It will not start the plant when switched on. On initial start-up, the system failure lamp will show momentarily as the pump produces a vacuum in the pipeline. This will change to system on as vacuum is produced. If the duty pump fails to produce vacuum e.g. if the overload has tripped etc., the duty pump will stop and the stand-by pump will start. If the stand-by pump produces vacuum in the pipeline, the Duty Failed lamp will show, indicating that the AGSS system is functioning but needs attention. If the stand-by pump also fails to produce vacuum, the System Failed lamp will show. The time from start-up (or loss of vacuum) is adjustable between approximately 1 & 8 seconds. Turn the timer anti-clockwise to increase the time. To return to normal operation after rectifying the fault on the duty pump, operate the Reset button on the control panel. The stand-by pump will stop and the duty pump will start. To change over duty pump, operate the Duty push button on the control panel. It is not possible to change duty onto a pump which has failed and caused the stand-by pump to operate until the system is reset. An alarm output in the form of volt-free~contacts, closed under normal operating conditions, rated at 50 V dc, 50mA. These contacts will open if the power fails or the duty pump trips.

Maintenance.

The filter on the balance vale must be cleaned or replaced periodically. The frequency of these inspections will depend on operating environment & should be determined by experience. Every 6 months. Isolate the plant & remove the motor fuses to prevent the pumps starting. Switch the power back on. Go to each remote control unit or other point at which the plant conditions are displayed in turn. Turn the plant on & check that the System Failed lamp comes on (remember to allow enough time for the duty pump to trip when checking the first remote control). Turn off the plant & repeat for all other control positions. Next isolate the pump and replace the motor fuses for motor 1 only. Switch on the power. Start the plant and wait for it to trip. Go to each remote control unit in turn. Switch on & check that the Duty Failed lamp is on. Reset the plant. Isolate and replace the fuses for pump 2.

Parts list

Pump	See name plate on pump mounting foot	Werner Reitschle or Esam
Balance valve	169835	Esam
Drain flask		Shire controls Ltd
Pressure switch	Vacuum 1/4BSP	Shire controls Ltd
Control panel box	HLN1540	Eldon
Control	PCBWAGD	Shire Controls Ltd
Contactora	01 044050 240	MTE
Overload	0 1 000130 0XX *	MTE
Alternatives:-		
Contactora	BF 16.40	Lovato
Overload	RF 25.*	Lovato
Fuse	130 XX*	Legrand
(*dependant on plant size)		
Fuse Holder	214 01	Legrand
Pushbutton	MP0031	Bulgin
Fuse F1 250mA ceramic	S501 250mA	Bussmann
Fuse F2 & F3 2A	S500 2A	Bussmann
Remote control unit	Simplex remote control unit	Shire Controls Ltd

DECLARATION OF CONFORMITY
89/392/EEC The Machinery Directive
73/23/EEC The Low Voltage Directive
89/336/EEC The EMC Directive

Manufacturer

Shire Controls Ltd
Studio 3, Channoeks Farm
Gilston, Harlow
Essex, CM20 2RL
United Kingdom Tel.01279 434399 Fax 01279 451706

Product Type

Duplex Anaesthetic Gas Scavenging Plant

ModelSerial No.....Voltage.....V

CurrentA Phases.....Frequency Hz 50

Maximum Prospective Fault Current.....KA

Drawing No WAGD5 issue 2

Year of manufacture

Standards used

BS EN 292 : part 1:1991 BS EN 292 : part 2:1991

BS EN 60204-1:1993 BS EN 50081-1

BS EN 50082-1 BS EN 61000-3-2

Authorised representative

I.R.Couchman Technical Director

Signature .

