

The SAX-6 Area Alarm for Piped Medical Gases

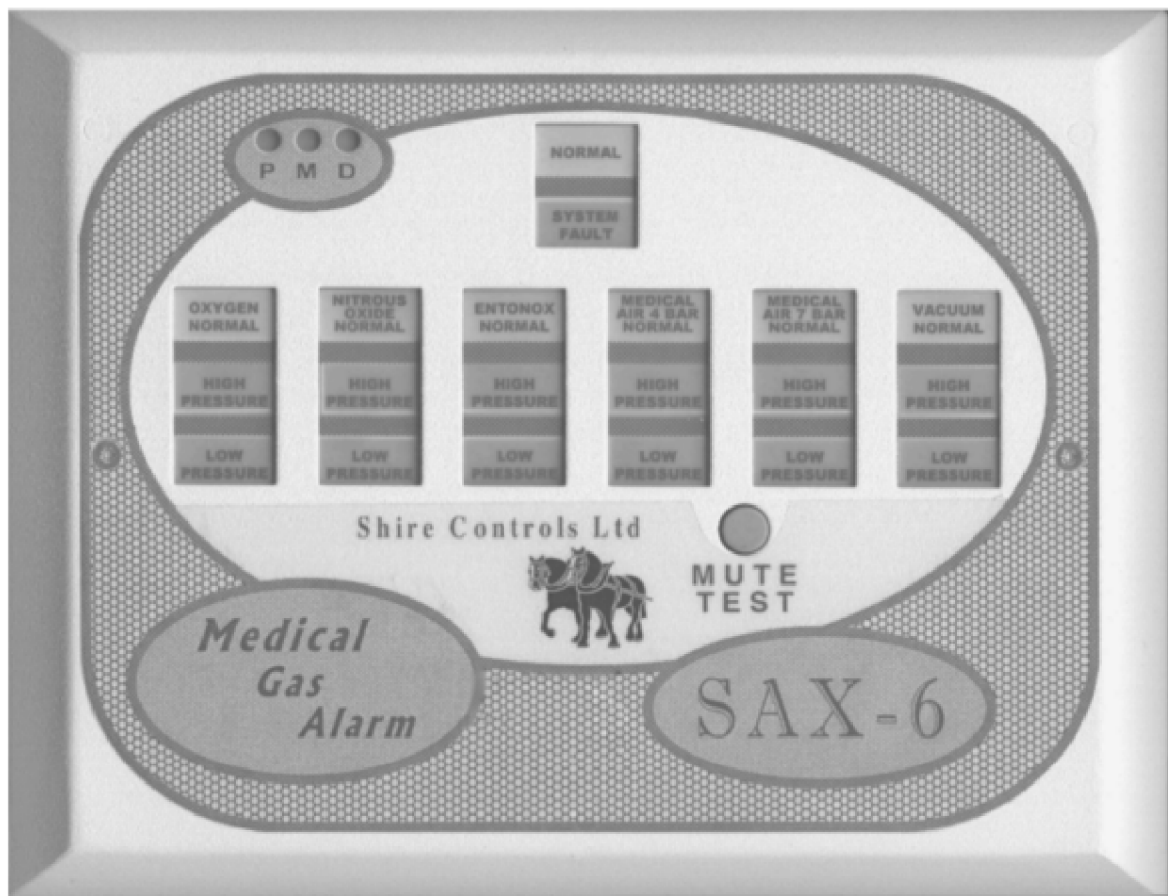

CE

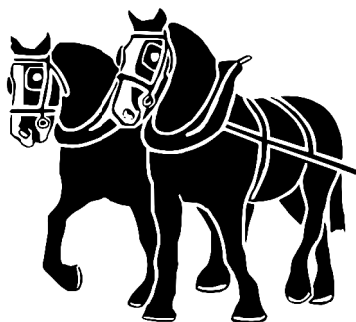

INTRODUCTION

The SAX-6 area alarm panel is designed to monitor high & low pipeline pressure on up to 6 gases, using volt-free, normally closed, contacts on pressure sensors mounted in the pipeline downstream from the final Area Valve Service Unit (AVSU). Each gas has a green normal, red high pressure and low pressure lamps. The panel also has a green power on lamp and a red system fault lamp, together with a mutable audible alarm. In addition, the panel has small status indicators to show how the panel is connected, and the status of the connection.

The SAX-6 can also receive and transmit data from & to the MEDCON bus as used by the SDX-15 plant alarm system. Note. An additional adaptor, which plugs into the main PCB, is required for operation with the SDX-15 system.

About this manual.



When you see this symbol, the associated text in **bold type** refers to something which may cause danger or damage.

Mounting.

Remove the front cover by removing the 2 M3 screws & lifting the cover clear. Disconnect the earth cable. Remove the PCB by removing the 2 M4 earth screws on the lower edge of the PCB and releasing the 2 clips on the upper edge. Unplug the mains flex.



NOTE. Always ensure that you are in contact with earth when handling electronic components to avoid damage by static discharges.

If cable entry is from behind the panel, remove the two knockouts in the back of the panel. Mount the panel with the TOP label uppermost, using the 4 holes provided.

Mount the termination box(if used) adjacent to the pressure switches. Plug the connectors on the flexes onto the pressure switches. Connect the 3 core screened cable from the alarm panel into the terminals marked A, B & C, ensuring that the screen is clamped using the copper clip provided.

CABLING.

The following connections are required:-

A 240 volt 50/60 Hertz supply, fused at 3 amps.



WARNING. This equipment is not suitable for connection to an IT power system. A readily accessible means of disconnecting the supply must be provided. The maximum prospective fault current must not exceed 1500 amps.

If the panel is to receive data directly from pressure switches, a 3 core screened cable, minimum 0.5 square mm, is required between the panel and the

termination box.

If the panel is to be connected to an SDX-15 system, a 2 core screened cable, minimum 0.5 square mm, is required between the panel and the nearest point on the SDX-15 system.

Notes



All cable screens must be connected at both ends. Continuity must be maintained through any junction boxes.

A minimum of 20mm clearance must be maintained between the alarm system cabling and any other cables (including the mains supply to the alarm system) FAILURE TO CARRY OUT THESE INSTRUCTIONS WILL RESULT INTERMITTENT FAULTS & WILL INVALIDATE THE DECLARATION OF CONFORMITY RELATING TO THIS EQUIPMENT

Connecting.

Note. The terminals for termination box & medcon connections can be unplugged for easy connection, by pulling the terminal down.

Connect the termination box(if used) to the three terminals marked PSW A B C. Also connect any other SAX-6 alarms panels which are to work with the same termination box (up to a maximum of 5 panels)

Connect the SDX-15 system (if used) to the terminals marked MEDCON 1 2.

Connect live, neutral & earth to the terminals marked L N and 

CONNECTING SCREENS

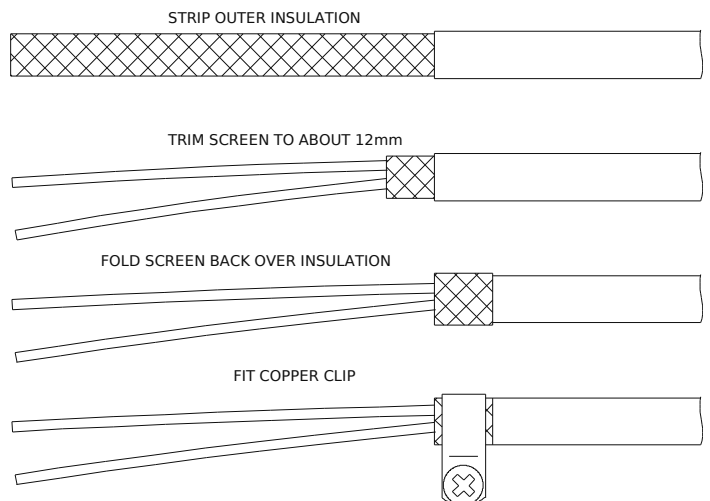

Replace the PCB by plugging in the mains flex, pressing the PCB onto the two mounting clips, and replacing the two earth screws on the lower edge. Remember to fit the crinkle washers! Plug in any terminals which have been removed for connection. Switch on the mains supply. Fit the battery isolating jumper across the 2 pins (see page 3)

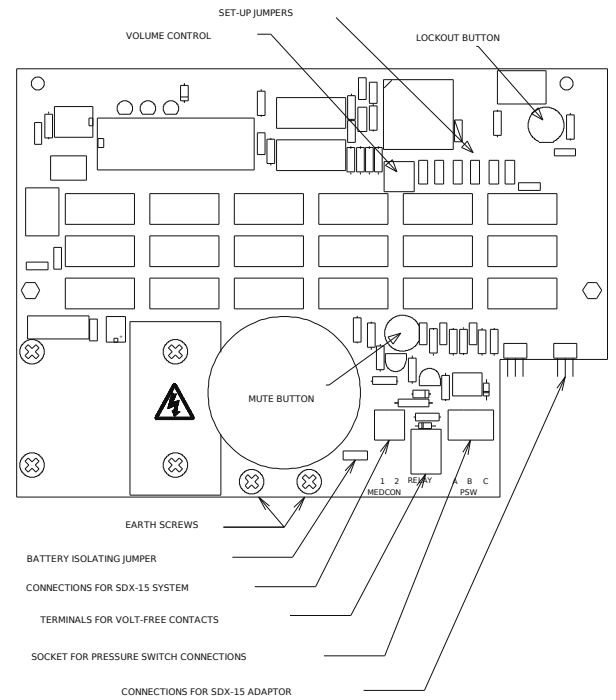
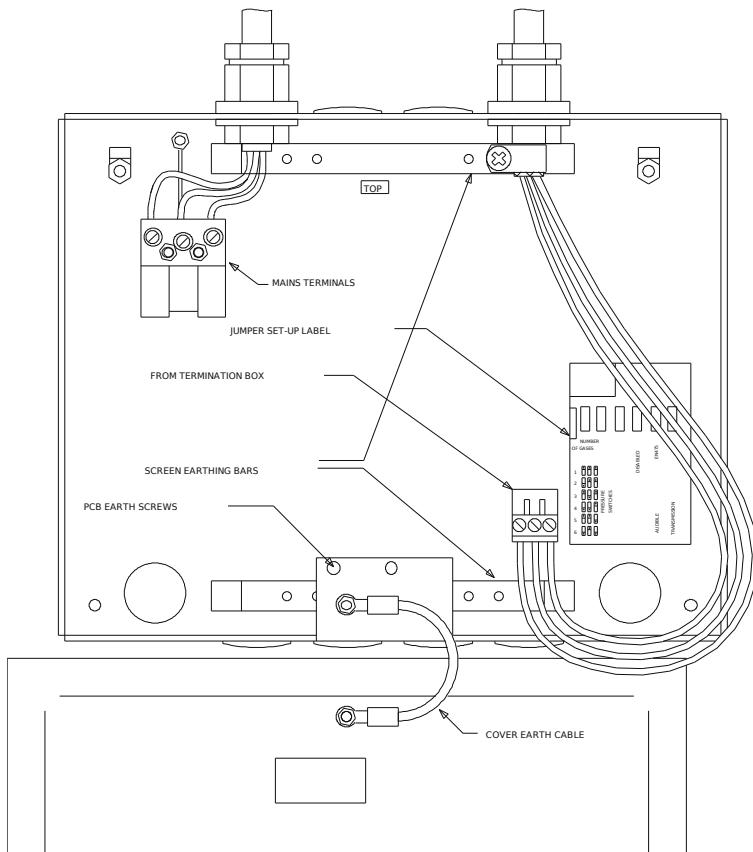

Setting up

Set the set-up jumpers as follows (the settings are shown on the label in the back box):-

Number of gases. You will not normally need to change these.

Pressure switches. Enable these if you are connecting to pressure switches via a termination box

Audible. Set to EN475 to enable the European standard audible type, or HTM02 to enable the HTM02 audible type.

Transmission. This is only used when transmitting or receiving data from the STD-15 alarm system. All sets the panel to transmit all alarm conditions, Common sets the alarm to transmit just a common alarm. See the information supplied with the SDX-15 adaptor for more details of setting up data transmission.

Set the volume control to the required level.

Replace the cover, ensuring that the earth lead is in place.

Operation

When a pressure switch opens due to a high or low pressure, the appropriate lamp will flash and the audible will sound. Operating the mute push button will silence the audible. If the alarm condition remains, the audible will re-trigger after about 15 minutes, requiring re-muting.

If an alarm condition will be present for an extended period, the alarm condition can be permanently muted as follows. Remove the cover while the alarm condition is present. Operate the

lockout button. Replace the cover. You can check which alarm conditions are locked out by pressing the mute/test button. Any alarm condition which is locked out will not flash. Any other alarm conditions will flash. Note. A system fault cannot be locked out

If pressure switch input is enabled (using the jumper) and no signals are received from the termination box, the red indicator marked P in the top left hand side of the alarm will flash, the system fault lamp will flash, all alarm conditions will fail to fault and the audible will sound. If signals are present, the indicator will be on continuously. If pressure switch input is not selected, the indicator will be off.

If an SDX-15 adaptor is fitted, it will be detected by the alarm panel. If no MEDCON signals are detected, the indicator marked M will flash, the system fault lamp will flash and the audible will sound. If signals are present, the indicator will be on continuously. If no adaptor is detected, the indicator will be off.

In the event of power failure, the internal battery will run the alarm. To conserve power, the lamp current is reduced, resulting in a drop in brightness. The audible will sound and the system fault lamp will flash. If the mains power is off for a prolonged period and the audible is not muted, all lamps will go out to conserve power. When the audible is muted or the mains power is re-instated, the lamps will return to normal operation.

Cable types

Use only the following types of cable for wiring the alarm system:-

SWA

Overall screened cable

Single core cable in steel conduit. Must not contain any other cables.

A minimum cable size of 0.5 sq.mm is recommended. Solid cable such as telephone cable should NOT be used.



Continuity of screen, armouring or conduit must be maintained at all times. Particular attention should be given to plastic junction boxes. Multicore cables must not be shared with other systems.

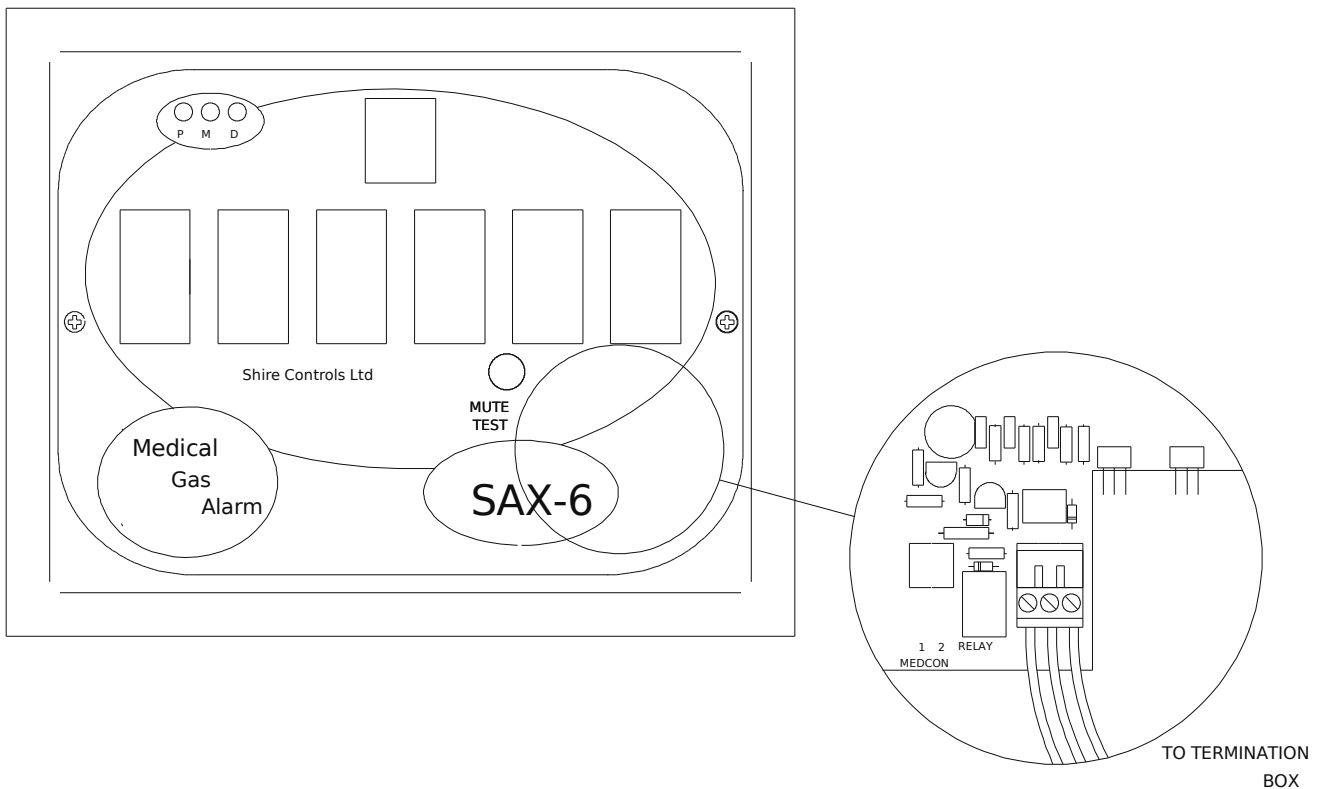
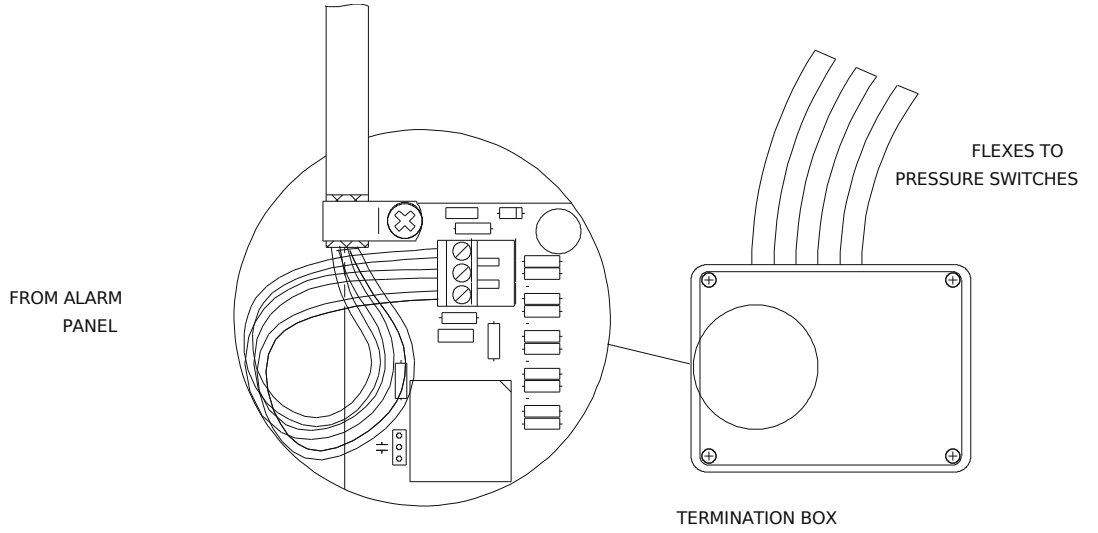

SETTINGS FOR MEDICAL APPLICATIONS

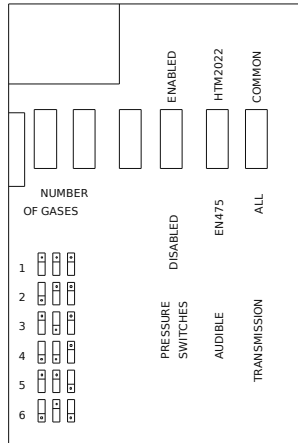

SETTINGS FOR INDUSTRIAL APPLICATIONS

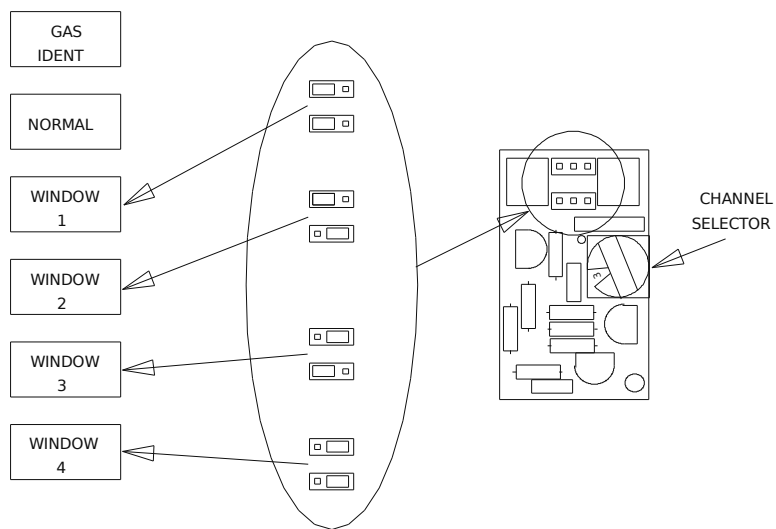
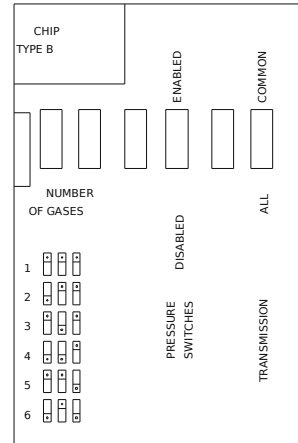

SETTINGS FOR USE WITH SDX-15 SYSTEMS

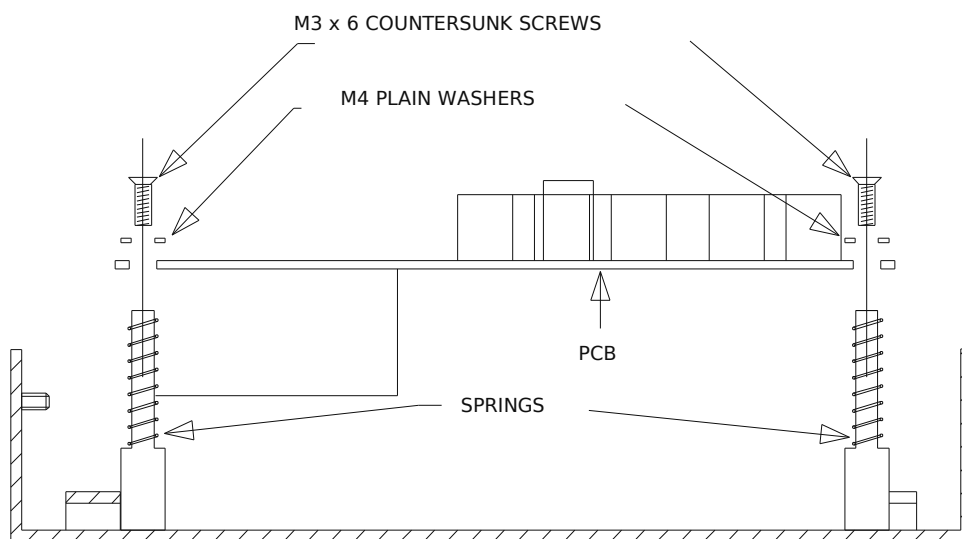

PCB FITTING FOR FLUSH MOUNTING PANELS

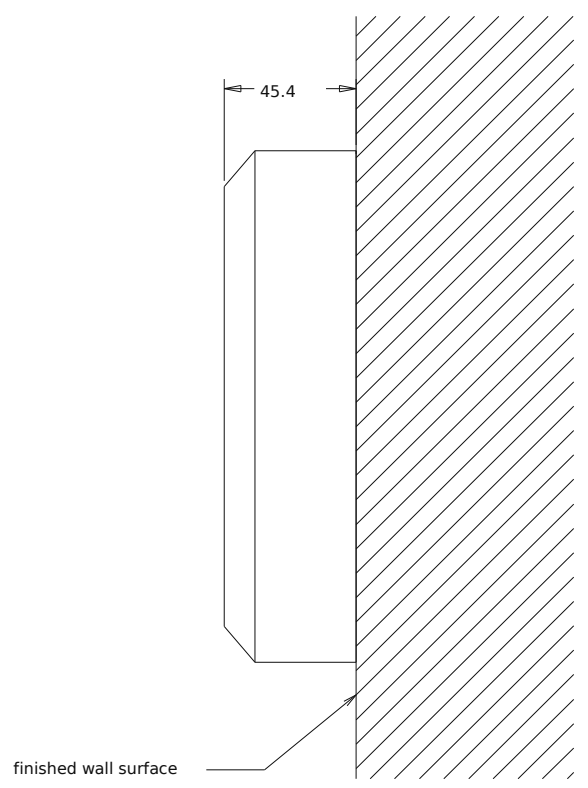
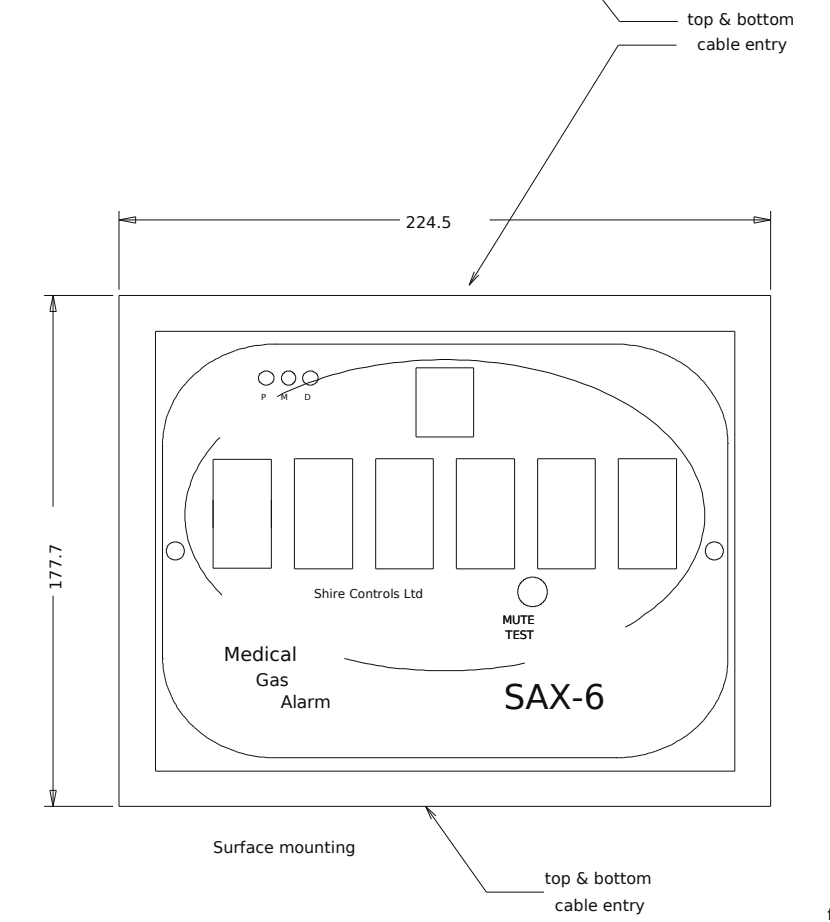
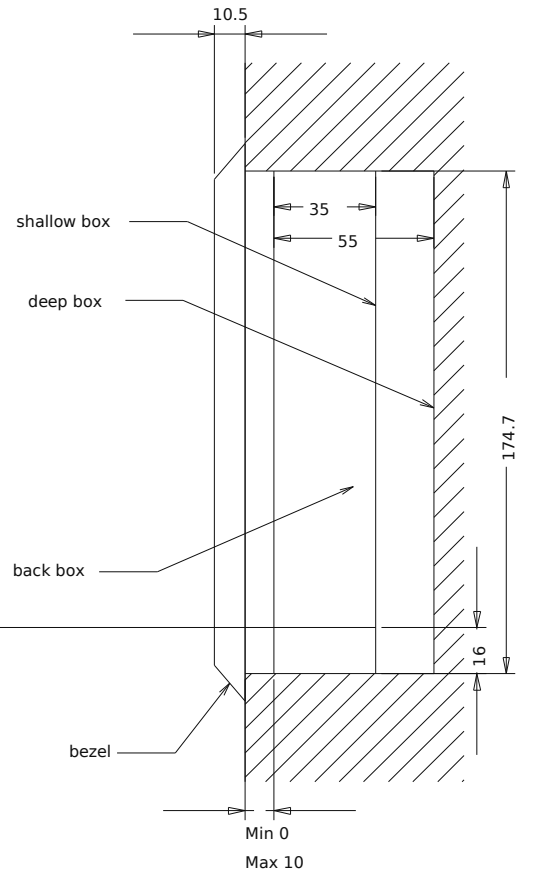
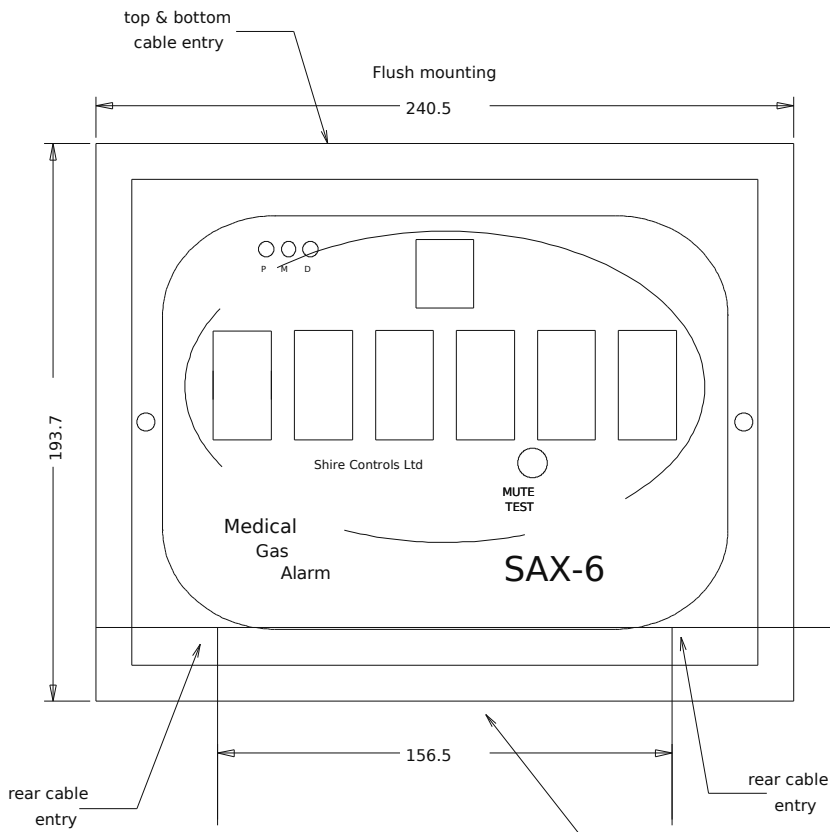

DECLARATION OF CONFORMITY

89/336 The EMC Directive

73/23 The Low Voltage Directive

Manufacturer

Shire Controls Ltd
Studio 3, Channoeks Farm, Gilston, Harlow
Essex CM20 2RL United Kingdom

Product Type

SAX-6 area alarm

Year of manufacture 2008

Standards used

BS EN 50081-1

BS EN 50082-1

BS EN 61000-3-2

BS EN 60950

Authorised representative I.R.Couchman

Technical Director

Signature



This work is licensed under the Creative Commons Attribution-NonCommercial 2.5 License. To view a copy of this license, visit <http://creativecommons.org/licenses/by-nc/2.5/> or send a letter to Creative Commons, 543 Howard Street, 5th Floor, San Francisco, California, 94105, USA.

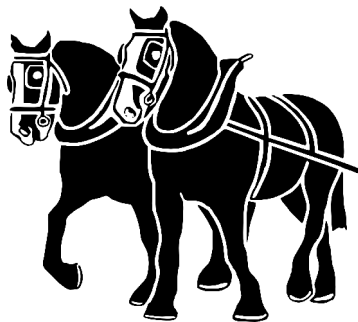

Shire Controls Ltd
Studio 3, Channoeks Farm
Gilston
Harlow
Essex
CM20 2RL

Tel. (01279) 434399

Fax. (01279) 451706

Website:

www.shirecontrols.com

or

www.shirealarms.co.uk