

The SDX-15 Alarm System

for

Piped Medical Gases

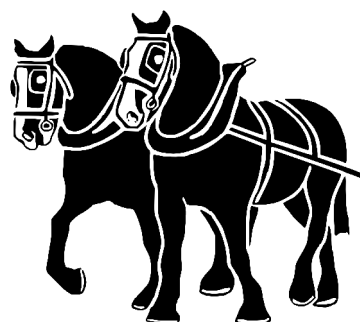
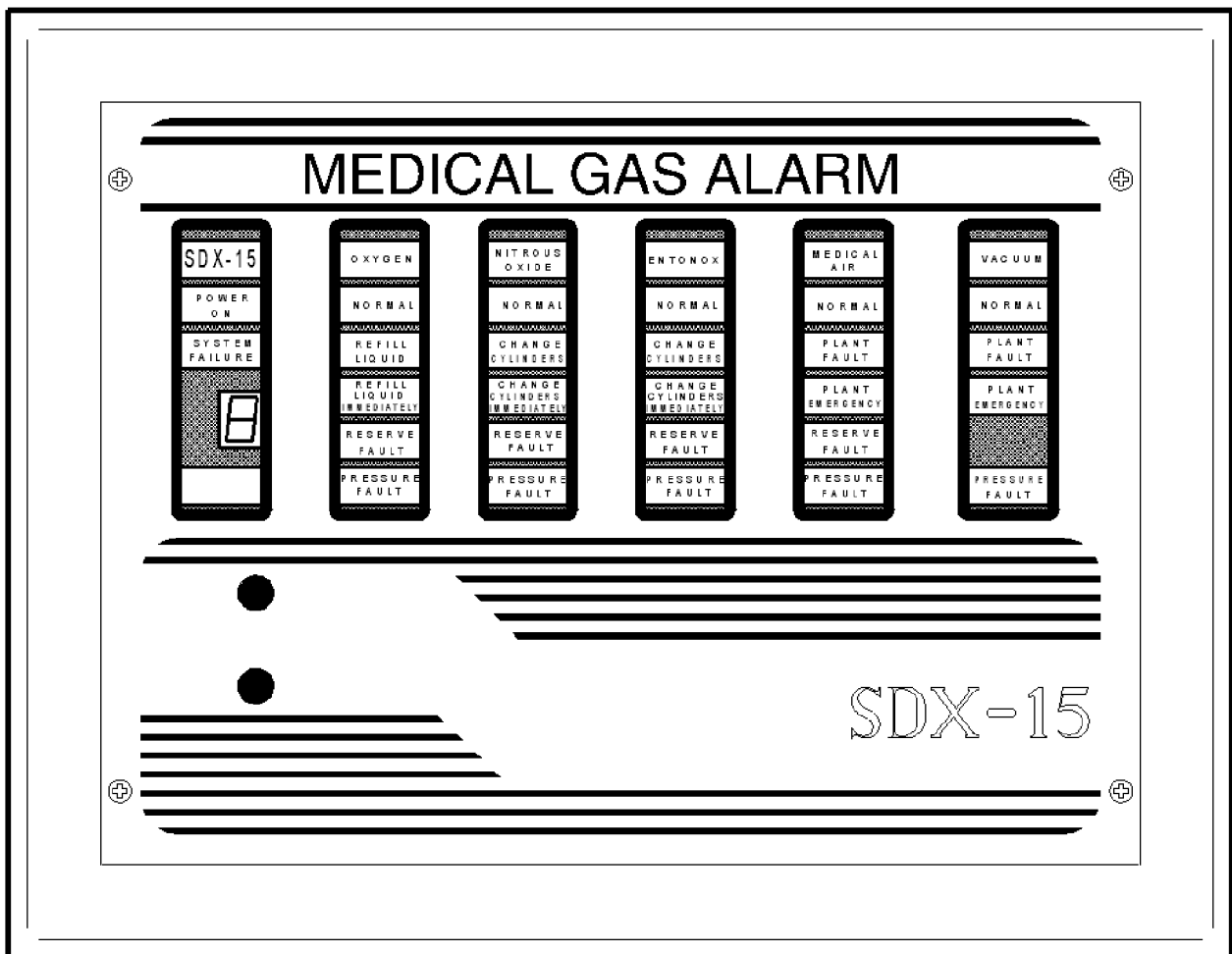

CE

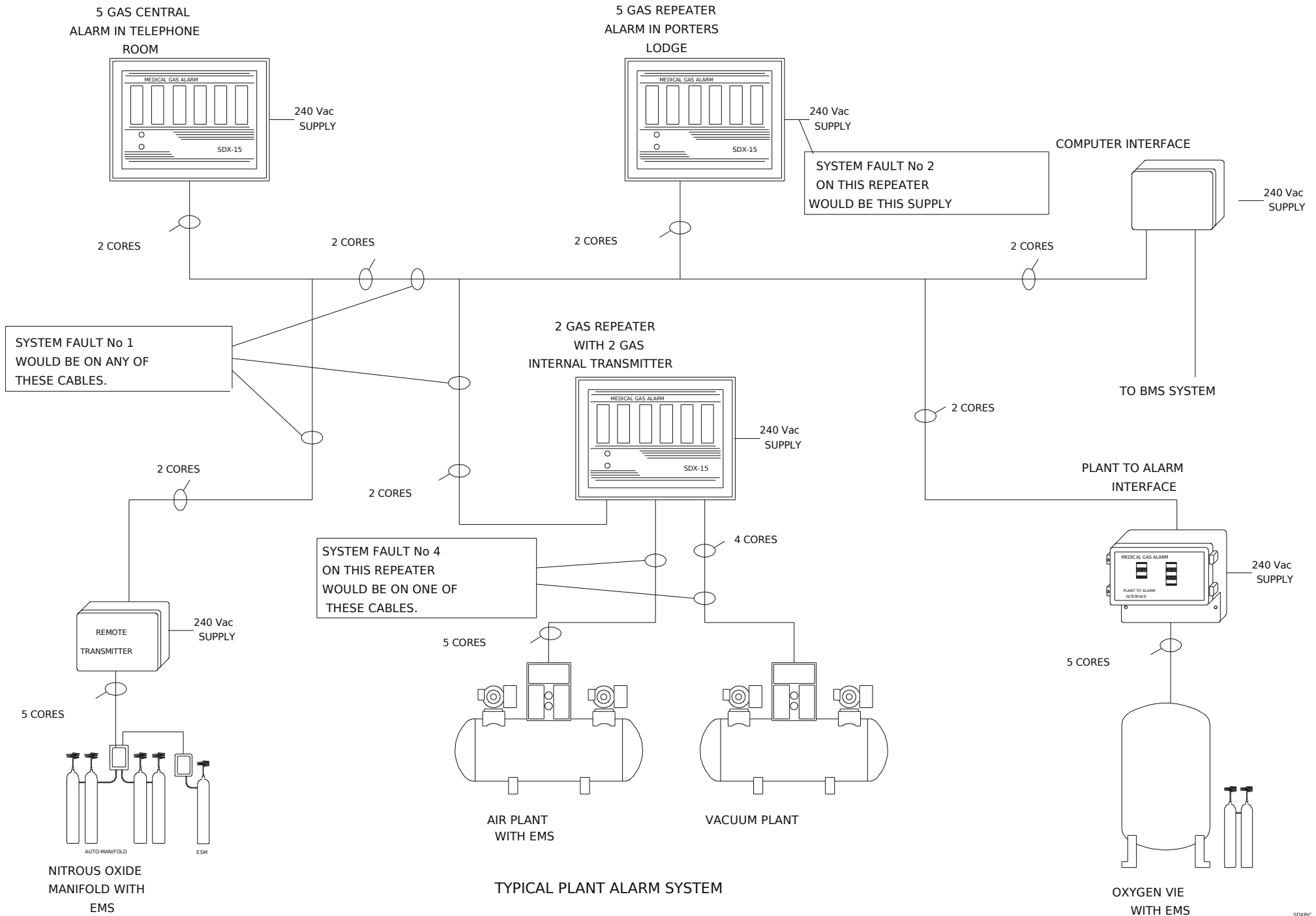

2

INTRODUCTION

The SDX-15 Medical Gas Alarm system has been developed to meet the requirements of Central & Repeater plant alarms as defined in DHSS. documents C11 & HTM02-01 and, as such, fully meets the requirements of these documents.

Emphasis is placed on reliability and flexibility, enabling an economical system to be installed and expanded as required. To this end, the manufacturers guarantee the availability of electrically compatible equipment for system expansion for a minimum of 10 years from the date of supply of the original system. The SDX-15 is fully compatible with existing SD-15 alarm systems. A full range of accessories is available allowing the system to be tailored to the requirements of the individual hospital.

About this manual.



When you see this symbol, the associated text in **bold type** refers to something which may cause danger or damage.

Section 2

SYSTEM DESCRIPTION

The SDX-15 Medical Gas Alarm system is a multiplexed system using the MEDCON data transmission standard, a pulse width modulated signal, on 2 core inter-panel wiring, capable of displaying up to 15 services, each consisting of up to 4 conditions plus normal. Any service may be split into four individual displays to be used to bring signals, such as the common alarm output from Area alarms, to a central point or to any point where this information is required.

Signals from plant or other monitored equipment are fed into the system via transmitters located adjacent to the equipment. A complete service can be transmitted from one transmitter or, if required (EMS for plant located remotely to the plant, for example), the service can be transmitted from several transmitters. The services are displayed at each panel as required, the service being selected by a rotary switch for each service within the panel.

Five long-life, 10 x 20mm block LEDs per service show the conditions of the service through a replaceable lens mounted behind a wipe-clean membrane. As an alarm condition occurs, the appropriate alarm condition will flash and the audible alarm will sound if selected by a 4 way

DIL switch for that service within the panel.

Operating the Mute switch on a repeater panel will silence the audible on that panel. Operating the Mute switch on the central panel will silence the audible on the central panel and convert the flashing lights to steady on all panels. (The audible on repeaters is not affected). If the condition remains, the audible will re-trigger, requiring re-muting. If a condition is to be in an alarm condition for a prolonged period, e.g. for pipeline maintenance, the re-trigger can be prevented by silencing the audible with the Lockout button within the panel. The audible will not then sound for that condition of that service until it has returned to normal and then back to alarm condition. A volume control is fitted within the panel.

A loud speaker is used for the audible rather than a buzzer, to give a mellow sound which, whilst drawing attention to the alarm condition, can be tolerated by staff otherwise occupied. Remote audible and muting units are available for use in areas where full display is not required or access to the panel is not possible.

Operation of the test button on the front of the panel will cause the normal lamps to illuminate, the alarm conditions to flash, the system fault lamp to flash and the audible to sound. Any fault condition which is locked out will not flash, showing at a glance if a condition has returned to normal operation. A seven segment display below the system fault lamp will also illuminate, showing which system fault, if any, is present (Power failure, data transmission failure, flashing circuit failure or contact line fault).

The alarm is housed in a steel enclosure (flush or surface mounting types are available) with a bezel which houses an aluminium front plate covered by a PVC membrane. Within the enclosure are mounted the power supply with battery reserve, control board with lamps, selector switches etc. and transmitter, if fitted. The front plate with control board is mounted on a hinge which allows the front to swing clear for connection or servicing, or reversed for access to the rear of the board and selector switches.

The battery reserve enables the system to remain in operation for up to 8 hours with only the lamps on the panel affected by the power failure out of operation, or for 4 hours if the panel is set for full backup. Computer interfaces are available to decode the multiplexed signals to volt-free contacts for connection to BMS systems or other alarm systems.

Section 3 TRANSMITTERS

Transmitters introduce signals from plant etc. onto the multiplexed signal wiring. They also monitor the wiring between the between the plant contacts and the transmitter terminals via termination boards mounted in or near the plant, checking for short or open circuits of the cable.

Internal transmitters are available as 1, 2, 3 or 4 service units and are mounted, 1 per 1-5 service alarm, in the alarm panel enclosure. If a fault is detected on the contact lines, an alarm condition is transmitted for the condition relating to the faulty line, and a system fault visual and audible alarm will appear on this panel.

Each service on the system is allocated a channel when the system is initially set up, this being entered on the log sheet. The alarm contacts on the plant or manifold are connected via the termination board to a service on the transmitter as follows:-

- | | |
|---|------------------|
| C | Common |
| 1 | First condition |
| 2 | Second condition |
| 3 | Third condition |
| 4 | Pressure fault |

and this service is then set to the channel for this service with the rotary switch. For example, if Oxygen is allocated channel 1, this plant could be connected to service A terminals on the transmitter, which would then be set to channel 1.

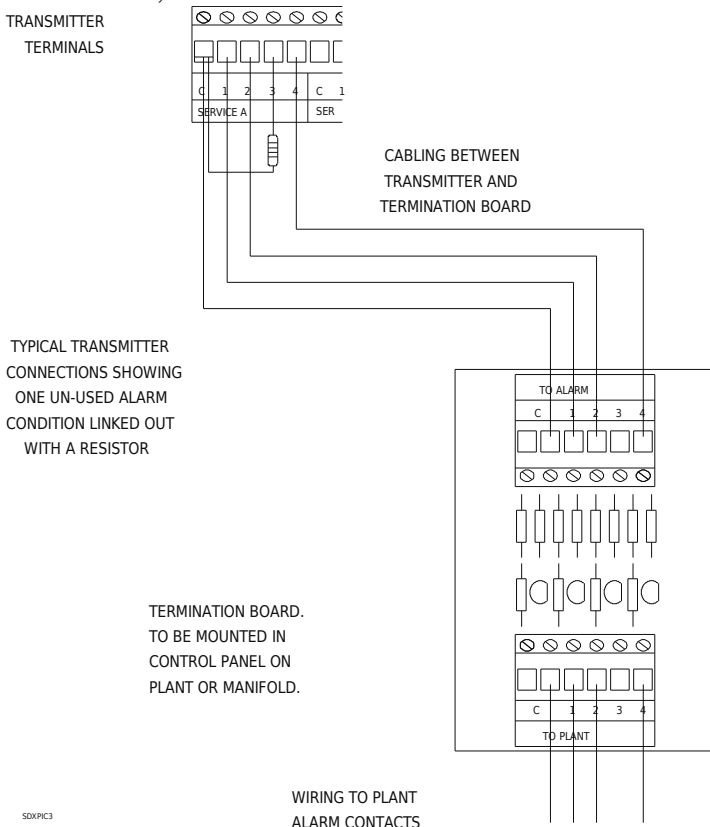

Any condition not transmitted from this transmitter must be terminated with a 56k resistor to set the condition to normal if the condition is not to be used, or with a 1k8 resistor if the condition is to be transmitted from another transmitter. The resistors are used to prevent a system fault due to short or open circuit. Note that if a resistor is fitted, the condition must NOT be connected to the termination board.

Resistor codes:-

- 1k8 brown grey red silver, gold or red
- 56k green blue orange silver, gold or red



It is important to ensure that any condition is only transmitted from one location although other conditions on the service may be transmitted from other transmitters.

Any service can be displayed on any alarm panel by selecting the channel on which the service is transmitted (by reference to the log sheet) using the rotary switch for the appropriate column on the panel.

Internal transmitters are powered by the alarm panel power supply or the reserve battery in the event of a power failure. Should the power remain off for long enough to discharge the battery, all conditions transmitted from this transmitter will show on other alarm panels as fault condition (not system fault).

Section 4 REMOTE TRANSMITTERS.

The Remote transmitter is a self contained unit, used where indication of the alarm condition is not required locally, e.g. when a manifold or plant has an integral plant to alarm interface, and are available as 1, 2, 3 or 4 service units. The services are selected, as in the alarm panel, with a rotary switch. However, the remote transmitter has only one switch for up to 4 services. This switch is set to the first service required and the other services will follow in sequence. e.g. if the switch on a 3 service transmitter is set to channel 2 then the services transmitted will be channels 2, 3 & 4. Connection to the plant is identical to the internal transmitter.

A 240 volt, 50/60 Hertz supply is required, which is connected to terminals under the mains terminal cover.

The 2 core inter-panel wiring is connected to signal terminals 1 & 2. The cable screen must be connected to the "S" terminal. Refer to the instruction sheet supplied with the transmitter for

further details.

Section 5 REMOTE AUDIBLES AND MUTES.

Alarm panels can be fitted with test&mute switches mounted remotely for situations where access to the panel is not practical e.g. when the alarm panel is mounted at high level. They should only be mounted in a position from which the alarm panel can be seen. The remote audible repeats the audible on the alarm panel to which it is connected, stopping when the audible is muted or the condition returns to normal. Whilst the audible is sounding, a visual indication, in the form of a red LED, will flash.

Three cores are required between the alarm panel and the remote audible, with connections made to the AUD, +Ve & -Ve terminals on the power supply board. If more than 2 remote audibles are to be operated from one alarm panel, a special booster power supply is required.

Section 6 COMPUTER INTERFACES.

Computer Interfaces are available which will give volt-free contacts which are closed when a condition is at normal. The relays are grouped in blocks of four, giving four conditions plus normal, which is closed only when all four conditions on that service are at normal. The services are selected, as in the alarm panel, with a rotary switch. However, the computer interface has only one switch for up to 5 services. This switch is set to the first service required and the other services will follow in sequence. e.g. if the switch on a 3 service interface is set to channel 2 then the services detected will be channels 2, 3,4 &5.

The computer interface is a self contained unit, supplied as a 1, 2, 3, 4 or 5 service unit. A 240 volt, 50/60 Hertz supply is required, which is connected to terminals under the mains terminal cover. The 2 core inter-panel wiring is connected to signal terminals 1 & 2. The cable screen must be connected to the ``S" terminal.

The rating of the relay contacts is 0.5 amp, 24 volt d.c. resistive.

NOTE. Each SDX-15 central or repeater alarm has an integral common alarm relay fitted as standard. This relay opens when any alarm condition or fault occurs on the panel.

Section 7 PLANT TO ALARM INTERFACE.

The plant to alarm interface is a low cost means of complying with the C11 & HTM02-01 requirements for indication of alarm status in plant or manifold room. It is mounted in a clear fronted polycarbonate enclosure protected to IP65, making it weatherproof and suitable for use in VIE compound etc. with no further protection. It consists of the following.

Four alarm conditions plus normal Power On & system fault lamps. A one gas transmitter, connected to the plant & set to the required channel in the same way as a standard transmitter. Four relays, giving volt-free contacts, closed under normal conditions, for connection to other alarm systems, BMS systems etc. A battery reserve to power the system failure lamp and the transmitter in the event of power failure.

The plant to alarm interface requires a 240 volt, 50/60 Hertz supply and connection to the two core inter-panel wiring. Note. Being a basic indicator, the plant to alarm interface has no audible alarm or test facility. Refer to the instruction sheet supplied with the plant to alarm interface for further details.

Section 8 SYSTEM DESIGN

If in doubt, please contact the manufacturers. Errors can easily be rectified at this stage!

The system must consist of a single central panel, which should be mounted in a area which is manned 24 hours a day. Select the number, location and size (number of services to be displayed) of alarm panel as required by C11/HTM02-01.

Select the location and size of transmitters. Use internal transmitters if an alarm panel is in the same room as the plant, or a remote transmitter if no additional local indication is required. Remember that a plant to alarm interface is cheaper than a one service repeater with internal transmitter for locations where local indication is required. With more than one service, a repeater with transmitter is more economical. The distance between the plant and the transmitter should be kept to a minimum, and in any case should not exceed 100 metres. See section 3 if conditions of a service are to be transmitted from more than one

location.

Transmitters are supplied with termination boards, which must be mounted in or adjacent to the plant. Select Computer interfaces, remote audibles etc. as required.

CABLING.

Two core cable as specified in appendix A, must be run between all alarm panels, remote transmitters, plant to alarm interfaces and computer interfaces. Cabling as specified in appendix A must be run between alarm condition source (plant, manifold etc.) and the transmitter from which the service is to be transmitted. One core per condition plus common are required for each service.



A minimum of 20mm clearance must be maintained between the alarm system cabling and any other cables (including the mains supply to the alarm system)

A 240 volt 50/60 Hertz supply, fused at 3 amps, from an essential supply, is required for each alarm panel, remote transmitter, plant to alarm interface and computer interface. Remote audibles require 3 cores from the alarm panel sourcing the audible signal. No 240 volt supply is required.

Section 8

INSTALLATION & COMMISSIONING.



WARNING. This equipment is not suitable for connection to an IT power system. A readily accessible means of disconnecting the supply must be provided. The maximum prospective fault current must not exceed 1500 amps.

Mount the surface or flush mounting boxes as required, following the mounting instructions supplied with each box. Fit bezel using countersunk screws supplied. Do not over tighten these screws. Install cable, observing cable entry areas as shown on the mounting instructions.



ALL CABLE SCREENS MUST BE CONNECTED TO EARTH. TERMINATION BOARDS MUST BE CONNECTED TO CABLE SCREENS OR EARTH. FAILURE TO CARRY OUT THESE INSTRUCTIONS WILL RESULT IN INTERMITTENT FAULTS & WILL INVALIDATE THE DECLARATION OF CONFORMITY RELATING TO THIS EQUIPMENT

Before connecting cabling on any panels, check continuity of cores and earth or screen, and insulation between cores and to earth.



Do not use high voltage testers such as meggers for these tests.

Connect Live, Neutral & Earth to terminals under the cover marked "ISOLATE MAINS BEFORE REMOVING COVER", making a cutout in the cover to suit the cable being used.



IMPORTANT. Ensure that the M4 screw below and to the left of these terminals is secure, as this is the earth connection to the box.

Replace the cover after connection. Connect the inter-panel signal wiring to terminals 1 & 2 on the power supply board, observing polarity. Ensure that the screen, armouring or conduit is connected by a sound connection to earth. Connect remote mute, test & audibles to terminals on the power supply as shown on the connection diagram supplied with the units.

Connect alarm condition cabling between transmitter & plant, terminating at the plant with a termination board.

SETTING UP.

Set the alarm panel at the central location as a central by placing the jumper between the centre & right hand pins on the central selector. Ensure that all other panels have the jumper between centre & left hand pin. Set the power failure mode as required using the jumper adjacent to the ribbon cable connector.

If the any alarm panel is to have full battery operation under power failure conditions, place the jumper between the centre and lower pins on the power selector. Allocate a channel for each service and enter the name of the service on the log sheet in the "Gas Service" column. It may be useful to allocate the services in the order in which they appear on the central panel, although this is not necessary. Go to each internal transmitter and set the rotary switch for each service to the channel allocated to that service on the log sheet. Set the rotary switch on each remote transmitter to the channel allocated to the first service on this transmitter. Set the channel for each computer interface as for remote transmitters.

Set the rotary switch on each plant to alarm interface to the appropriate channel. For each alarm panel, set the rotary switch for each service displayed on the panel to the channel allocated to

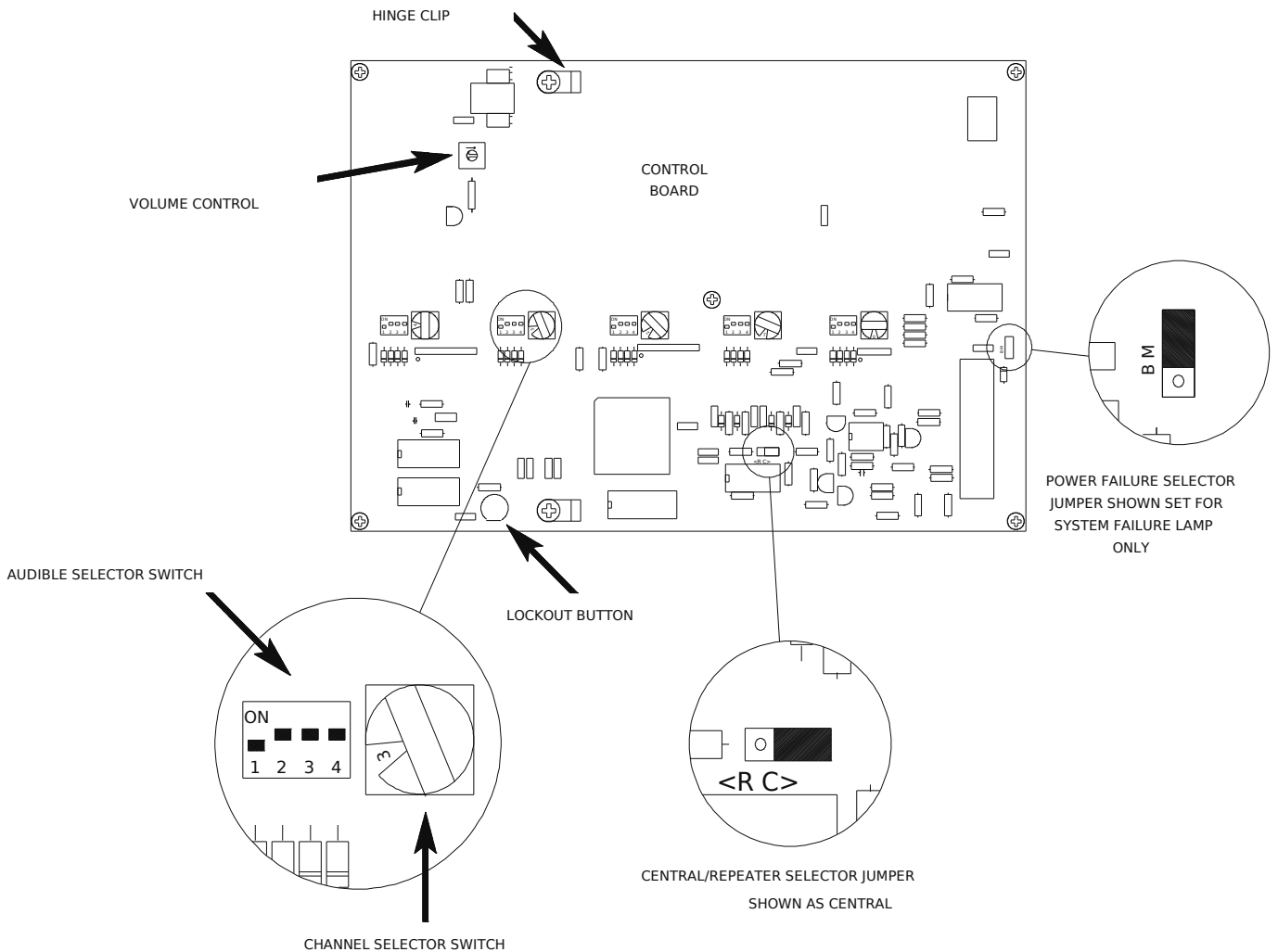

that service.

If a column is not required e.g. if a spare service has been installed for future use, set the rotary switch to "F" which switches off that column. Set the four audible switches for each service as required. (switch number 1 is condition 1, the first lamp below normal. If a switch is on, the audible for that condition will operate, otherwise it will never sound.)

Mount the front plate & PCB onto the hinge by springing the ends of the hinge apart & fitting into the clips on the PCB. Plug the ribbon cable on the power supply into the control PCB. (it is keyed to prevent incorrect connection). Switch on the power to all panels, transmitters etc. and connect the battery cables. (OBSERVE POLARITY). The system should now be operational. Note that no panels will operate if the central panel is not functioning. In this case, all repeater panels will show an Incoming Signal (number 1) on the system fault display when the test button is pushed. This will also happen if the inter-panel wiring is reversed at any panel or the wiring is short circuited. Disconnect each panel in turn until the fault clears. If it does not, check for short circuits.

If a Contact Line fault (number 4) is indicated, check that resistors are fitted in all unused conditions on the transmitter, that the termination boards are fitted and the cabling between termination board and transmitter is not short or open circuit.

If a Power Failure (number 2) is indicated, check the 240 volt supply to the panel and the two fuses on the power supply board.

When all panels are on, each condition in turn should be created at the plant to confirm the

operation and setting of the system. When it is not possible to create a condition e.g. from a pressure switch on a pipeline which is in use, disconnect the condition on the plant side of the termination board. When satisfied that all conditions operate correctly, **anti confusion tests must be carried**



out by creating alarm conditions on each service in turn and confirming that each panel on which the service is displayed operates correctly.

Section 9 OPERATION & TESTING.

All that is required for routine operation is for staff to mute the audible alarm on alarm panels in their areas as required, taking any action required by the nature of the service fault. The audible will resound periodically as long as the service fault remains, requiring re muting.

When a condition is to be at alarm condition for a long time, the audible can be continuously muted as follows. Open the panel and, while the alarm condition is present, press the white push button on the rear of the control board. Note that any other conditions present at the time will also be locked out. Close the panel and confirm that the condition has been successfully locked out by pressing the test button. All other lamps should flash, the locked out condition(s) being steady. The lockout will cancel as soon as the condition returns to normal. NOTE. This operation should only be carried out by service personnel.

TESTING

Periodically operate the test button and ensure that all lamps illuminate and the audible sounds. Periodically disconnect the mains supply to each panel and ensure that the system fault lamp flashes and the audible sounds. Provided that the battery in the panel under test is sound and fully charged, no other panel will be affected by this test. Any remote audible connected to the alarm panel under test will sound.

SECTION 10 FAULT FINDING.



WARNING. STATIC SENSITIVE DEVICES. OBSERVE HANDLING PRECAUTIONS.

Properly installed, the SDX-15 alarm system will give many years of trouble-free service. Experience shows that the majority of problems are due to incorrect connection or poor workmanship during installation. Problems with intermittent faults are usually due to screens not connected to earth, badly made connections or water-filled junction boxes.

Most problems will be identified by the system fault indicator below the system fault lamp, which will illuminate when the test button is pressed. See appendix B to decode these numbers.

If no lamps show when the test button is pressed, check that the power supply is present at the panel and that the battery is not discharged. (a discharged battery will take about 72 hours to fully recharge).

Flashing circuit has failed.

Fit a service exchange control PCB.

Incoming Signal fault.

If this fault is present on all panels on the system, using an analog voltmeter on a 10 volt DC range, measure the voltage across terminals 1 & 2 on the central panel. If no voltage is present, disconnect the signal wiring from terminals 1&2 on the central panel and repeat the test. If a voltage of between about 2 -8 volts is now present then a short circuit exists on the signal wiring or a repeater panel has been wired with the signal wires reversed (check the polarity of the wiring with the meter with the signal wires disconnected from the repeater. Number 1 should be positive). Reconnect the central panel and disconnect each part of the signal wiring until the fault clears. The last part of the wiring to be disconnected has the fault on it. If no voltage was present at the central panel after disconnecting the signal wires, first ensure that the panel is set to be a central. If it is then fit a service exchange board.(Remember. A board can be "borrowed" from another, less critical, location and used to get a system running!) If the system fault only appears on one section of the system, look for a broken wire or loose terminal between the section with the system fault and the rest of the system.

Contact Line fault.

This indicates that the wiring between the transmitter in the alarm panel showing the system fault, and the termination board is open or short circuit. A service fault will be showing at the same time. This fault (or faults) indicates which cable

Appendix A Cable types

Use only the following types of cable for wiring the alarm system:-

SWA

Overall screened cable

Single core cable in steel conduit. Must not contain any other cables.

A minimum cable size of 0.5 sq.mm is recommended. Solid cable such as telephone cable should NOT be used.



Continuity of screen, armouring or conduit must be maintained at all times. Particular attention should be given to plastic junction boxes. Multicore cables must not be shared with other systems.

Appendix B System Faults

- 0. No fault
- 1. Incoming signal fault
- 2. Power failure
- 3. Incoming signal and power faults
- 4. Contact line fault
- 5. Contact line and incoming signal faults
- 6. Contact line and power faults
- 7. Contact line, power&incoming signal faults
- 8. Flashing circuit failed
- 9. Flashing circuit&incoming signal faults

DECLARATION OF CONFORMITY

89/336 The EMC Directive

73/23 The Low Voltage Directive

Manufacturer

Shire Controls Ltd
Studio 3, Channoeks Farm
Gilston Harlow
Essex
CM202RL
United Kingdom

ProductType

SDX-15 Medical Gas Alarm system, including internal and remote transmitters, plant to alarm interfaces, computer interfaces&remote audibles.

Year of manufacture 2008

Standards Used

BS EN 50081-1

BS EN 50082-1

BS EN 61000-3-2

BS EN 60950

Authorized representative I.R.Couchman, Technical Director

Signature



has the problem on it. e.g. if a panel is showing a number 4 system fault and say, pressure fault on nitrous oxide, the cable connected to condition 4 on the nitrous oxide service on the transmitter is broken or shorted to common or earth. Note that unused inputs to transmitters must be connected to common with a resistor to prevent a system fault (see section 3).

Power Failure.

Check that the mains supply is sound. If sound, check the fuses on the power supply board and replace as necessary. If sound, fit service exchange boards.



IMPORTANT NOTE. If any control or transmitter boards are replaced, ensure that the replacement boards are set for the correct channels.

Carry out anti-confusion tests when work is complete.

Flush Mounting box

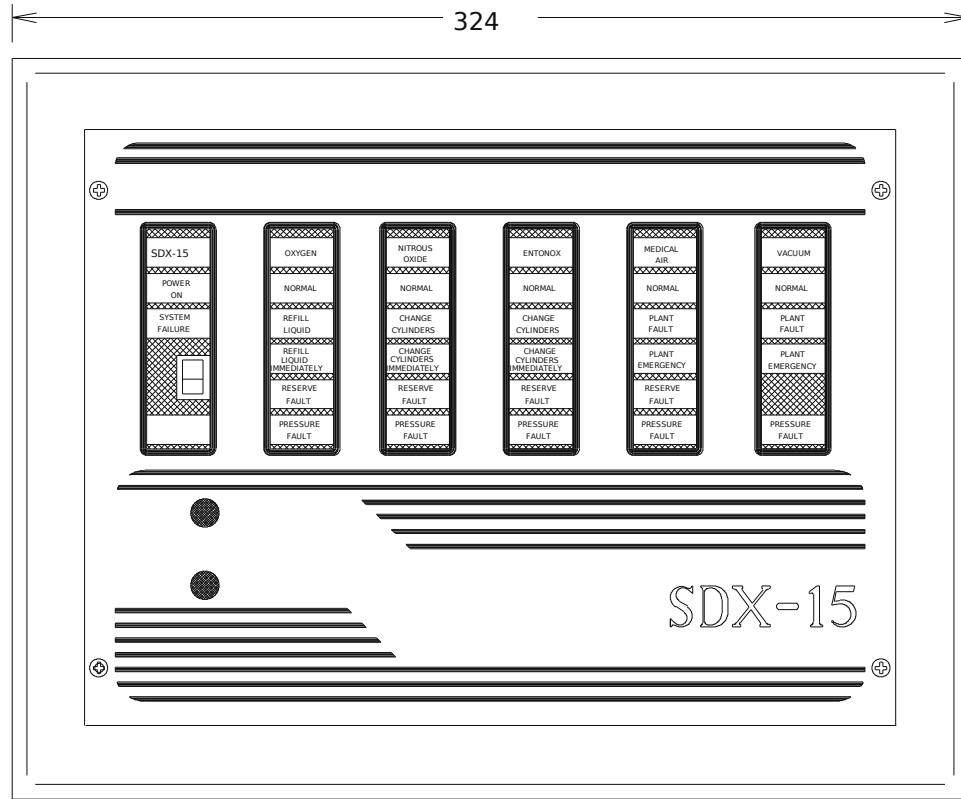

BEZEL .

SECTIONAL VIEW OF FIXINGS

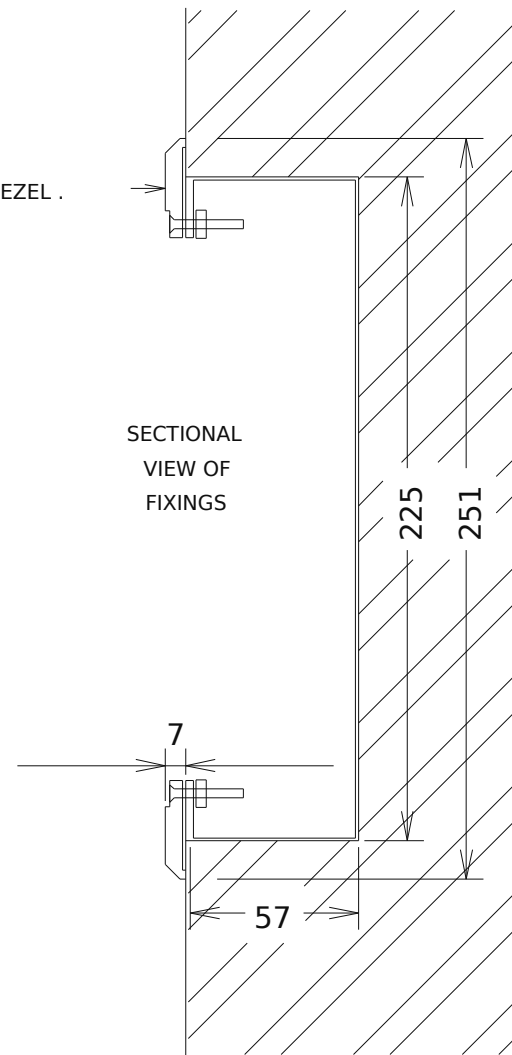

CABLE ENTRIES

MAINS

MEDCON SIGNALS

TRANSMITTER SIGNALS

BOTTOM VIEW

BACK BOX

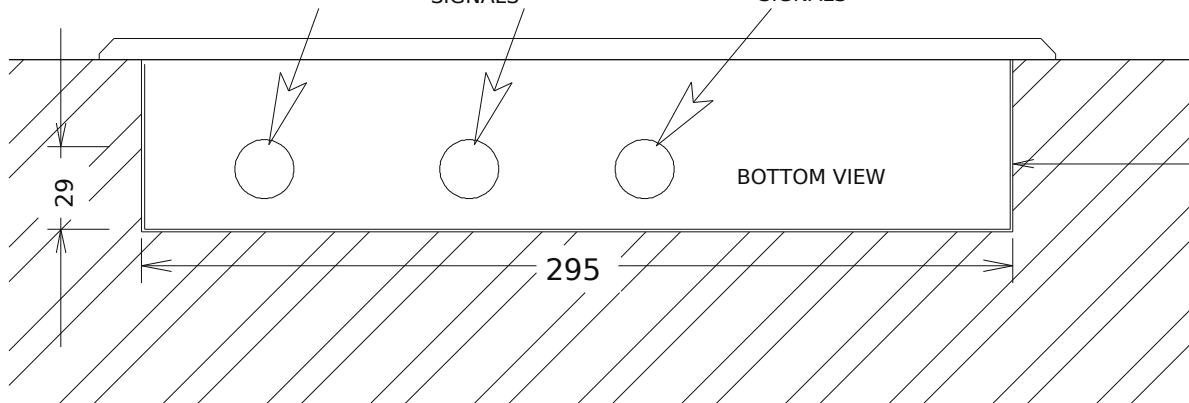

Surface Mounting box

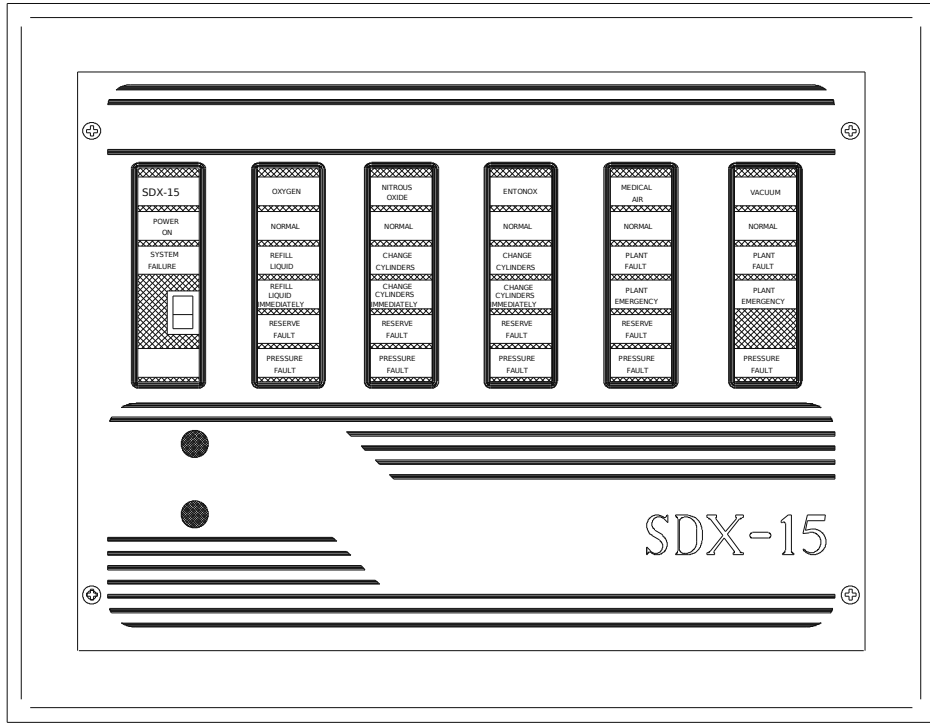

251

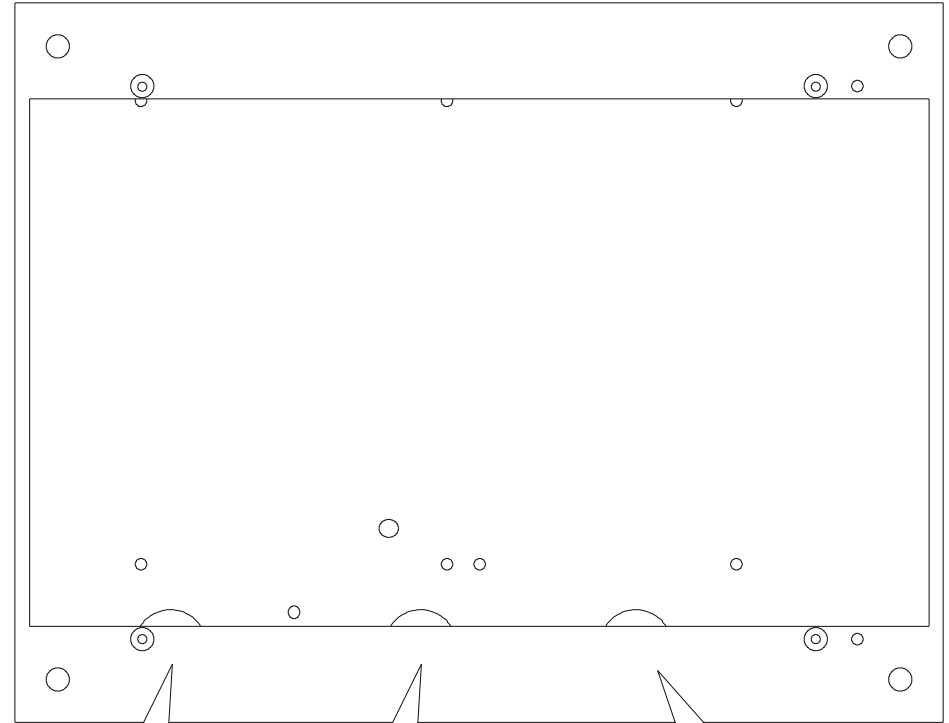
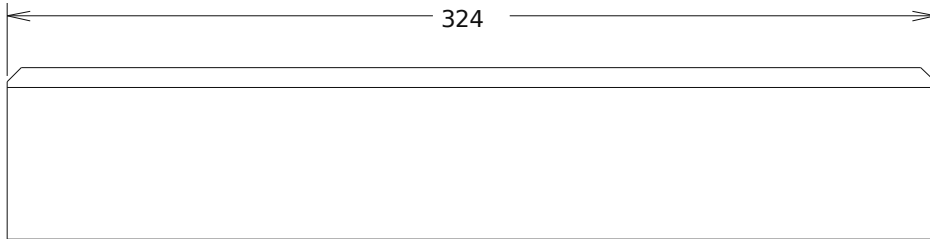

MAINS

MEDCON SIGNALS

TRANSMITTER SIGNALS

CABLE ENTRIES

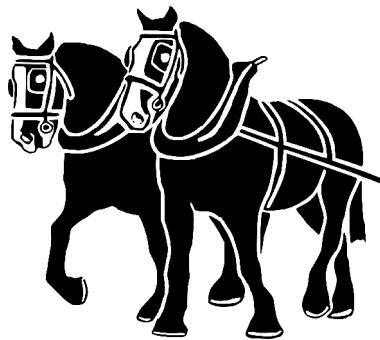

Shire Controls Ltd
Studio 3, Channoeks Farm
Gilston
Harlow
Essex
CM20 2RL

Tel. (01279) 434399
Fax. (01279) 451706
www.shirecontrols.com
or
www.shirealarms.co.uk



This work is licensed under the Creative Commons Attribution-NonCommercial 2.5 License. To view a copy of this license, visit <http://creativecommons.org/licenses/by-nc/2.5/> or send a letter to Creative Commons, 543 Howard Street, 5th Floor, San Francisco, California, 94105, USA.